



CC3500 SERIES CONCRETE SAW

*C*essco *I*nc.

Toll Free 1-800-882-4959

35 HP Service Saw

Ideal for municipalities
and rental stores

Utilizes many of the same
heavy-duty components we use
on our bigger saws

Fits through a 30" door!

Strongest
frame
on the
market

Choice of 14"
through 30"
blade guards

Maximum cutting depth
12-3/8" with 30" guard

Available with a 20 HP or 30
HP electric motor.

Features Wisconsin
35 HP gasoline engine



CORE CUT® large saws
feature convenient one
hand saw control.

Large Concrete Saws



CC3500 SPECIFICATIONS



CC3500 Control Panel
(shown with optional shaft tachometer and lowering speed metering valve)

Cutting Depth Chart

Blade Diameter	14"	20"	26"	30"
Cutting Depth	4-3/8"	7-3/8"	10-3/8"	12-3/8"

CC3500 Specifications

Maximum Depth of Cut: 12-3/8"
Blade Shaft Diameter: 1-3/4"
Arbor Diameter: 1" with single drive pin
Blade Shaft Bearings: Self-aligning double concave roller
Blade Shaft Drive: 6 belt
Blade Mounting: Right or left
Blade Raise and Lower: Electro-hydraulic pump
Blade Coolant: Dual multi-spray tubes
Blade Guard Attachment: Slip-on
Front Wheel Dimensions: 6" x 2" x 1"
Rear Wheel Dimensions: 8" x 2-1/2" x 1-1/4"
Handle Bars: Tilt
Transmission: Sundstrand-Sauer
Drive Speed: 0-200 feet per minute
Air Filter: 4 stage
Fuel Capacity: 6 gallons
Electric Start: Standard
High Temperature Shut-Off: Standard
Hour Meter: Standard
Tachometer: Optional
Amp Meter: Standard
Cutting Depth Indicator: Standard
Quick Disconnect Blade Flanges: Standard
Frame Lift: Standard
Telescoping Front Pointer: Standard

CC3500 Saws

Model No.	Engine Type	Part No.	Cat. No.	Blade Capacity	Uncrated Wt.*
CC3535-6-14	35 HP Wisconsin	5800094	02265	14"	1,090 lbs.
CC3535-6-20	35 HP Wisconsin	5800095	02267	20"	1,100
CC3535-6-26	35 HP Wisconsin	5800096	02268	26"	1,110
CC3535-6-30	35 HP Wisconsin	5800097	02269	30"	1,120
CC3530E-6-14	30 HP Lincoln Electric (460v) †	5800334	48439	14"	1,035
CC3530E-6-20	30 HP Lincoln Electric (460v) †	5800335	48440	20"	1,045
CC3530E-6-26	30 HP Lincoln Electric (460v) †	5800336	48441	26"	1,055
CC3530E-6-30	30 HP Lincoln Electric (460v) †	5800337	47813	30"	1,065
CC3520E-6-14	20 HP Baldor Electric * †	5800098	48442	14"	1,005
CC3520E-6-20	20 HP Baldor Electric * †	5800099	02271	20"	1,015
CC3520E-6-26	20 HP Baldor Electric * †	5800100	02272	26"	1,025
CC3520E-6-30	20 HP Baldor Electric * †	5800101	02273	30"	1,035

* Specify 230V or 460V. 575V or 50 cycle motors available on request. † Includes motor starter switchbox.

* add 70 pounds for crated weight

Quick-release bladeshaft/flange, slip-on blade guards and double concave roller bearings are standard on all CC3500 saws.

CC3500 Options

Description	P/N	Cat. No.
Free Wheeling Clutch *	6011038	02510
Water Safety Switch	6047932	47451
Water Pump (electric)	6011032	02506
Parking Brake	6011228	81191
Spot Light	6010112	02427
Magnetic Spot Light	6011170	47551
Vertical Muffler	2700296	00681
Shaft Tachometer	6010226	02479
Lowering Speed Metering Valve	6010227	02480
Soft Start Controller Add On **	6010228	02491
Extended Blade Shaft Kit for spacing blades 3/4" to 1-1/2"	6011185	48094
Extended Blade Shaft Kit for spacing blades 1-1/2" to 2-1/4"	6011186	02482
Extra Slip-On Blade Guards:		
14" Capacity	6010070	02395
20" Capacity	6010072	02397
26" Capacity	6010074	02398
30" Capacity	6010076	02399

* Standard on all electric saw models.

** For electric saws-factory installed

CC3500 Dimensions

A Saw Height	47-1/4"
B Min Length Pointer Up, Handle In	55-1/2"
C Max Length Pointer Down, Handle Out	112"
D Handle Extension	24"
E Frame Width	23-3/8"
F Frame Length	39-1/2"
G Saw Width	29-7/8"
H Front Axle Center Length	18-1/2"
I Rear Axle Center Length	20-3/4"
J Wheel Base Length	18-1/4"
K Blade Shaft Max Height	16-1/2"

Crated Saw Dimensions:

52" long x 34" wide x 54-1/2" high

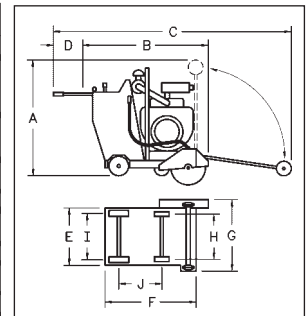

Large Concrete Saws

