



CC4000D SERIES CONCRETE SAW

with Differential Drive and Optional Multi-Speed Blade System

Adjust blade speeds quickly and easily

*C*essco *I*nc.

Toll Free 1-800-882-4959

Revolutionary easy access blade drive system allows you to quickly adjust blade speeds

Available with single or multi-speed blade drive

Choice of 35 HP Wisconsin gas engines or 30 HP Lincoln electric motors

Fits through a 30" door



Maximum cutting depth 12-3/8" with a 30" guard

Differential drive system allows for easy maneuverability. No heavy lifting to turn saw.

Choice of 14", 20", 26" and 30" blade guards

CC4000D Advantages

- ◆ Easy to turn and maneuver thanks to the differential drive system. No heavy lifting to turn saw.
- ◆ Hydrostatic transmission with differential is totally enclosed. No exposed chains or gears.
- ◆ Differential lock provides positive drive to both rear wheels for maximum traction.
- ◆ All CC4000D saws come standard with quick-release bladeshaft/flange, slip-on blade guards, quick-release 10" rear wheels, double concave roller bearings, telescoping front pointer and 3 position handle bars.
- ◆ Bladeshaft tachometer standard.
- ◆ Free wheel neutral on hydrostatic transmission for manual maneuvering.
- ◆ 4 stage air cleaner with maintenance indicator for maximum engine protection.



Easy accessible pulleys located in the front of the saw for quick saw speed adjustment

CC4000D SPECIFICATIONS

CC4000D Saws						
Model	Engine Type	Part No.	Cat. No.	Blade Cap.	Blade Speeds	Uncrated Wt.*
CC4035DM-14	35 HP Wisconsin (multi-speed drive)	5800451	48007	14"	14" thru 30"	1,090
CC4035DM-20	35 HP Wisconsin (multi-speed drive)	5800452	47320	20"	14" thru 30"	1,100
CC4035DM-26	35 HP Wisconsin (multi-speed drive)	5800453	48446	26"	14" thru 30"	1,110
CC4035DM-30	35 HP Wisconsin (multi-speed drive)	5800454	47383	30"	14" thru 30"	1,120
CC4035D-14	35 HP Wisconsin (single speed drive)	5800455	48447	14"	14"	1,090
CC4035D-20	35 HP Wisconsin (single speed drive)	5800456	48448	20"	20"	1,100
CC4035D-26	35 HP Wisconsin (single speed drive)	5800457	48449	26"	26"	1,110
CC4035D-30	35 HP Wisconsin (single speed drive)	5800458	46916	30"	30"	1,120
CC4030EDM-14	30 HP Lincoln Electric 460V (dual speed drive)*	5800459	48450	14"	14" and 26"	1,090
CC4030EDM-20	30 HP Lincoln Electric 460V (dual speed drive)*	5800460	47023	20"	20" and 30"	1,100
CC4030EDM-26	30 HP Lincoln Electric 460V (dual speed drive)*	5800461	48451	26"	14" and 26"	1,110
CC4030EDM-30	30 HP Lincoln Electric 460V (dual speed drive)*	5800462	48452	30"	20" and 30"	1,120

All CC4000D saws come standard with quick-release bladeshaft/flange, slip-on blade guards, shaft tachometer, quick-release rear wheels and double concave roller bearings.
* 575V available upon request.

* Add 70 pounds for crated weight



CC4000D Control Panel

CC4000D Specifications	
Maximum Depth of Cut:	12-3/8"
Blade Shaft Diameter:	1-3/4"
Arbor Diameter:	1" with single drive pin
Blade Shaft Bearings:	Self-aligning double concave roller
Blade Shaft Drive:	6 belt for model CC4000D
Blade Shaft Drive:	8 belt for model CC4000DM
Blade Mounting:	Right or left
Blade Raise and Lower:	Electro-hydraulic pump
Blade Coolant:	Dual multi-spray tubes
Blade Guard Attachment:	Slip-on
Front Wheel Dimensions:	6" x 2" x 1"
Rear Wheel Dimensions:	10" x 3" x 1"
Handle Bars:	3 Position
Transmission:	Eaton Model 7
Drive Speed:	0-200 feet per minute
Air Filter:	4 stage
Fuel Capacity:	6 gallons
Electric Start:	Standard
High Temperature Shut-Off:	Standard
Hour Meter:	Standard
Tachometer:	Standard
Amp Meter or Volt Meter:	Standard
Cutting Depth Indicator:	Standard
Quick Disconnect Blade Flanges:	Standard
Frame Lift:	Standard
Quick Release Rear Wheels:	Standard
Telescoping Front Pointer:	Standard

Cutting Depth Chart

Blade Diameter	14"	20"	26"	30"
Cutting Depth	4-3/8"	7-3/8"	10-3/8"	12-3/8"

CC4000D Options

Description	P/N	Cat. No.
Water Safety Switch	6047932	47451
Water Pump (electric)	6011032	02506
Spot Light	6010112	02427
Magnetic Spot Light	6011170	47551
Vertical Muffler	2700296	00681
Lowering Speed Metering Valve	6010227	02480
Soft Start Controller Add On*	6010228	02481
Extended Blade Shaft Kit for spacing blades 3/4" to 1-1/2"	6011185	48434
Extended Blade Shaft Kit for spacing blades 1-1/2" to 2-1/4"	6011186	48141
Extra Slip-On Blade Guards:		
14" Capacity	6010070	02395
20" Capacity	6010072	02397
26" Capacity	6010074	02398
30" Capacity	6010076	02399

* Factory installed

CC4000D Dimensions

A Saw Height	44-1/2"
B Min Length Pointer Up, Handle In	47"
C Max Length Pointer Down, Handle Out	100"
D Handle Extension	20"
E Frame Width	24"
F Frame Length	36-1/2"
G Saw Width*	31"
H Front Axle Center Length	19"
I Rear Axle Center Length	21"
J Wheel Base Length	17"
Blade Shaft Max Height	16-1/2"

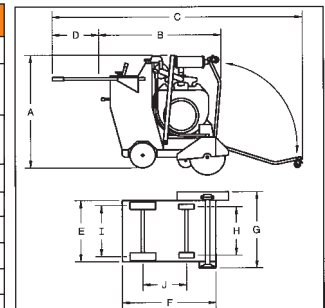

* Saw width is reduced by removing blade guard.
Crated Saw Dimensions: 52" L x 34" W x 51" H



Large Concrete Saws

