



# CC7100 SERIES CONCRETE SAW

*Cessco Inc.*

Toll Free 1-800-882-4959

## Turbo Charged Diesel Production Concrete Saw

Longer life, lower maintenance engine than 65 HP gasoline engine

Features Deutz 78 HP turbo charged diesel engine

Forward-positioned motor for more weight at blade and less on the operator

Better fuel economy and much higher sawing rates than a normal 65 HP gasoline engine



Choice of 14" through 42" blade guards

Excellent for bridge deck and parapet sawing



Comes standard with shaft tachometer

Extra heavy-duty reinforced single piece frame, designed specifically for the Deutz engine

16-3/4" maximum cutting depth with a 42" guard

Large Concrete Saws



# CC7100 SPECIFICATIONS



CC7100 Control Panel

CC7100 Specifications	
Maximum Depth of Cut:	16-3/4"
Blade Shaft Diameter:	1-3/4"
Arbor Diameter:	1" with single drive pin
Blade Shaft Bearings:	Self-aligning double concave roller
Blade Shaft Drive:	10 Belt
Blade Mounting:	Right or left
Blade Raise and Lower:	Electro-hydraulic pump
Blade Coolant:	Dual multi-spray tubes
Blade Guard Attachment:	Slip-on through 30" guard, bolt on 36" and 42"
Front Wheel Dimensions:	8" x 3" x 1"
Rear Wheel Dimensions:	10" x 3" x 1-1/4"
Handle Bars:	Tilt
Transmission:	Eaton Model 10
Drive Speed:	0-200 feet per minute
Air Filter:	4 stage
Fuel Capacity:	9 gallons
Electric Start:	Standard
High Temperature Shut-Off:	Gauge and warning light alerts operator
Low Oil Alert:	Warning light alerts operator
Hour Meter:	Standard
Tachometer:	Standard
Amp Meter:	Warning light alerts operator
Cutting Depth Indicator:	Standard
Quick Disconnect Blade Flanges:	Standard
Frame Lift:	Standard
Quick Release Rear Wheels:	Standard
Telescoping Front Pointer:	Standard

Cutting Depth Chart						
Blade Diameter	14"	20"	26"	30"	36"	42"
Cutting Depth	4-5/8"	7-5/8"	10-5/8"	11-3/4"	14-3/4"	16-3/4"

CC7100 Saws						
Model No.	Engine Type	Part No.	Cat. No.	Blade Capacity	Uncrated Wt.*	
CC7172-10-14	78 HP Deutz Diesel	5800220	02321	14"	1790 lbs.	
CC7172-10-20	78 HP Deutz Diesel	5800221	47703	20"	1800	
CC7172-10-26	78 HP Deutz Diesel	5800222	02322	26"	1810	
CC7172-10-30	78 HP Deutz Diesel	5800223	48513	30"	1820	
CC7172-10-36	78 HP Deutz Diesel	5800224	02323	36"	1830	
CC7172-10-42	78 HP Deutz Diesel	5800225	47494	42"	1850	

\* add 125 pounds for crated weight.

CC7100 Options		
Description	P/N	Cat. No.
Water Safety Switch	6010522	67821
Water Pump (electric)	6011032	02506
Spot Light	6010112	02427
Magnetic Spot Light	6011170	47551
Lowering Speed Metering Valve	6010227	02480
Extended Blade Shaft Kit for spacing blades 3/4" to 1-1/2"	6010249	48094
Extended Blade Shaft Kit for spacing blades 1-1/2" to 2-1/4"	6010229	02482
Parking Brake	6011228	81191
Extra Blade Guards:		
14" Capacity (slip on)	6010070	02395
20" Capacity (slip on)	6010072	02397
26" Capacity (slip on)	6010074	02398
30" Capacity (slip on)	6010076	02399
36" Capacity	6010260	47088
42" Capacity	6010143	02442

CC7100 Dimensions		
A	Saw Height	63"
B	Min Length Pointer Up, Handle In	61"
C	Max Length Pointer Down, Handle Out	126"
D	Handle Extension	24"
E	Frame Width (Rear)	27-5/8"
F	Frame Width (Front)	37"
G	Frame Length	51"
H	Saw Width	43-1/4"
I	Front Axle Center Length	31"
J	Rear Axle Center Length	24-1/2"
K	Wheel Base Length	23-7/8"
L	Blade Shaft Max Height	22-1/2"

**Crated Saw Dimensions:**  
64" long x 44" wide x 70" high

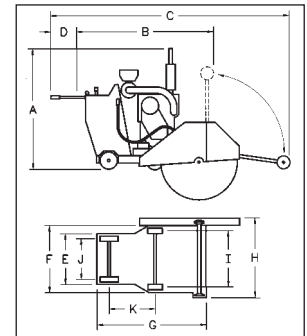

Large Concrete Saws