

OPERATION AND PARTS MANUAL



Mikasa SERIES
MODEL MVH-206D
REVERSIBLE PLATE COMPACTOR
(YANMAR L70V6GF1R1AA ENGINE)

Revision #0 (06/17/08)

To find the latest revision of this
publication, visit our website at:
www.multiquip.com



THIS MANUAL MUST ACCOMPANY THE EQUIPMENT AT ALL TIMES.



CALIFORNIA — Proposition 65 Warning

Engine exhaust and some of its constituents are known to the State of California to cause cancer, birth defects and other reproductive harm.

TABLE OF CONTENTS

MVH-206D REVERSIBLE PLATE COMPACTOR

Proposition 65 Warning	2
Table of Contents	4
Parts Ordering Procedures	5
Safety	6-7
Rules and Regulations	8-10
Specifications	11
Dimensions	12
General Information	13
Controls and Components	14
Basic Engine	15
Inspection	16-17
Operation	18-20
Maintenance	21-25
Troubleshooting	26-27
Explanation of Code in Remarks Column	28
Suggested Spare Parts	29

COMPONENT DRAWINGS

Nameplate and Decals	30-31
Vibrating Plate Assy	32-33
Base and Engine Assy	34-37
Vibrator Assy	38-39
Control Assy	40-43

YANMAR L70V6GF1R1AA DRAWING

Cylinder Block Assy	44-47
Air Cleaner Assy	48-49
Muffler Assy	50-51
Crankshaft and Camshaft Assy	52-53
Piston Assy	54-55
Lub. Oil, Pump and Governor Assy	56-57
Cooling and Starting Device Assy	58-59
Fuel Injection Pump Assy	60-61
Fuel Tank and Fuel Line Assy	62-63
Tools, Labels and Gaskets Assy	64-65
Accessories	66-67
Terms and Conditions of Sale - Parts	68

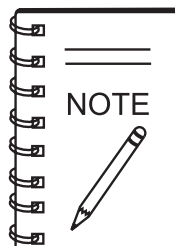

Specification and part number are subject to change without notice.

PARTS ORDERING PROCEDURES

Ordering parts has never been easier! Choose from three easy options:

Effective:
January 1st, 2006



Order via Internet (Dealers Only):

Order parts on-line using Multiquip's SmartEquip website!

- View Parts Diagrams
- Order Parts
- Print Specification Information



If you have an MQ Account, to obtain a Username and Password, E-mail us at: parts@multiquip.com.

To obtain an MQ Account, contact your District Sales Manager for more information.

Goto www.multiquip.com and click on

Order Parts to log in and save!

Use the **internet** and qualify for a **5% Discount** on *Standard orders* for all orders which include complete part numbers.*

Note: Discounts Are Subject To Change



Order via Fax (Dealers Only):

All customers are welcome to order parts via Fax.

Domestic (US) Customers dial:
1-800-6-PARTS-7 (800-672-7877)

Fax your order in and qualify for a **2% Discount** on *Standard orders* for all orders which include complete part numbers.*

Note: Discounts Are Subject To Change



Order via Phone: Domestic (US) Dealers Call:
1-800-427-1244

Non-Dealer Customers:

Contact your local Multiquip Dealer for parts or call 800-427-1244 for help in locating a dealer near you.



International Customers should contact their local Multiquip Representatives for Parts Ordering information.

When ordering parts, please supply:

- | | |
|---|--|
| <input type="checkbox"/> Dealer Account Number | <input type="checkbox"/> Specify Preferred Method of Shipment: |
| <input type="checkbox"/> Dealer Name and Address | <input checked="" type="checkbox"/> UPS/Fed Ex <input checked="" type="checkbox"/> DHL |
| <input type="checkbox"/> Shipping Address (if different than billing address) | <input checked="" type="checkbox"/> Priority One <input checked="" type="checkbox"/> Truck |
| <input type="checkbox"/> Return Fax Number | <input checked="" type="checkbox"/> Ground |
| <input type="checkbox"/> Applicable Model Number | <input checked="" type="checkbox"/> Next Day |
| <input type="checkbox"/> Quantity, Part Number and Description of Each Part | <input checked="" type="checkbox"/> Second/Third Day |

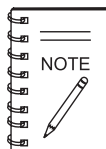

All orders are treated as *Standard Orders* and will ship the same day if received prior to 3PM PST.

WE ACCEPT ALL MAJOR CREDIT CARDS!



www.multiquip.com



FOR YOUR SAFETY AND SAFETY OF OTHERS!

Safety precautions should be followed at all times when operating this equipment. Failure to read and understand the Safety Messages and Operating Instructions could result in injury to yourself and others.

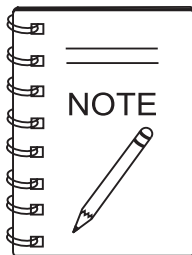

This manual has been developed to provide complete instructions for the safe and efficient operation of this equipment. Refer to the engine manufacturer's instructions for data relative to its safe operation.

Before using this equipment ensure that the operating individual has read and understood all instructions in this manual.

SAFETY MESSAGE ALERT SYMBOLS

The three Safety Messages shown below will inform you about potential hazards that could injure you or others. The Safety Messages specifically address the level of exposure to the operator, and are preceded by one of three words: **DANGER**, **WARNING**, or **CAUTION**.

DANGER

You **WILL** be **KILLED** or **SERIOUSLY INJURED** if you **DO NOT** follow these directions.

WARNING

You **CAN** be **KILLED** or **SERIOUSLY INJURED** if you **DO NOT** follow these directions.

CAUTION

You **CAN** be **INJURED** if you **DO NOT** follow these directions.

HAZARD SYMBOLS

Potential hazards associated with the operation of this equipment will be referenced with Hazard Symbols which appear throughout this manual, and will be referenced in conjunction with Safety Message Alert Symbols.

WARNING — Lethal Exhaust Gas Hazards



Engine fuel exhaust gases contain poisonous carbon monoxide. This gas is colorless and odorless, and can cause death if inhaled. **NEVER** operate this equipment in a confined area or enclosed structure that does not provide ample free flow air.

WARNING — Explosive Fuel Hazards



Fuel is extremely flammable and its vapors can cause an explosion if ignited. **DO NOT** start the engine near spilled fuel or combustible fluids.

DO NOT fill the fuel tank while the engine is running or hot. **DO NOT** overfill tank, since spilled fuel could ignite if it comes into contact with hot engine parts or sparks from the ignition system. Store fuel in approved containers, in well-ventilated areas and away from sparks and flames.

WARNING — Burn Hazards



Engine components can generate extreme heat. To prevent burns, **DO NOT** touch these areas while the engine is running or immediately after operation. Never operate the engine with heat shields or heat guards removed.

WARNING — Respiratory Hazards



ALWAYS wear approved respiratory protection when required.

⚠ CAUTION — Rotating Parts Hazards



NEVER operate equipment with covers or guards removed. Keep fingers, hands, hair and clothing away from all moving parts to prevent injury.

⚠ CAUTION — Accidental Starting Hazards



ALWAYS place the equipment ON/OFF switch in the OFF position when the equipment is not in use.

⚠ CAUTION — Eye and Hearing Hazards



ALWAYS wear approved eye and hearing protection when required.

⚠ CAUTION — Overspeed Conditions



NEVER tamper with the factory setting of the engine governor. Personal injury and equipment damage can result if operating in speed ranges above the maximum allowable.

⚠ CAUTION — Equipment Damage Hazards

Other important messages are provided throughout this manual to help prevent damage to your equipment, other property, or the surrounding environment.

RULES AND REGULATIONS

WARNING — Read This Manual

Failure to follow instructions in this manual may lead to serious injury or even **DEATH!** This equipment is to be operated by trained and qualified personnel only! This equipment is for industrial use only.

GENERAL SAFETY

- **DO NOT** operate or service this equipment before reading this entire manual.



- This equipment should not be operated by persons under 18 years of age.

- **NEVER** operate this equipment without proper protective clothing, shatterproof glasses, steel-toed boots and other protective devices required by the job.



- **NEVER** operate this equipment when not feeling well due to fatigue, illness or when under medication.



- **NEVER** operate this equipment under the influence of drugs or alcohol.



- **NEVER** disconnect any "**emergency or safety devices**". These devices are intended for operator safety. Disconnection of these devices can cause severe injury, bodily harm or even death! Disconnection of any of these devices will void all warranties.

- **NEVER** use accessories or attachments that are not recommended by Multiquip for this equipment. Damage to the equipment and/or injury to user may result.

- Manufacturer does not assume responsibility for any accident due to equipment modifications. Unauthorized equipment modification will void all warranties.

- Whenever necessary, replace nameplate, operation and safety decals when they become difficult read.

- **ALWAYS** check the equipment for loosened threads or bolts before starting.

- **NEVER** touch the hot exhaust manifold, muffler or cylinder. Allow these parts to cool before servicing engine or pump.



- **ALWAYS** allow the engine to cool before adding fuel or performing service and maintenance functions. Contact with *hot* components can cause serious burns.

- **NEVER** operate this equipment in any enclosed or narrow area where free flow of the air is restricted. The engine of this equipment requires an adequate free flow of cooling air. If the air flow is restricted it will cause serious damage to the equipment or engine and may cause injury to people and property. Remember the engine gives off **DEADLY** gases.



- **ALWAYS** refuel in a well-ventilated area, away from sparks and open flames.

- **ALWAYS** use extreme caution when working with **flammable** liquids. When refueling, **stop** the engine and allow it to cool.

- **DO NOT** smoke around or near the equipment. Fire or explosion could result from fuel vapors, or if fuel is spilled on a hot engine.



- **NEVER** operate the equipment in an explosive atmosphere or near combustible materials. An explosion or fire could result causing severe **bodily harm or even death**.



- **DO NOT** top-off fuel tank. Topping-off is dangerous as it causes fuel to spill.

- **ALWAYS** store the equipment in a clean, dry location out of the reach of children.

- **NEVER** run engine without air cleaner. Severe engine damage may occur.

- **NEVER** leave the equipment unattended with the engine running. Turn off engine when unattended.

- **CAUTION** must always be observed while servicing this equipment. Rotating parts can cause injury if contacted.

RULES AND REGULATIONS

LOADING AND UNLOADING

- Before lifting, make sure that equipment parts (hook and vibration insulator) are not damaged and screws are not loosened or lost.
- **ALWAYS** make sure crane or lifting device has been properly secured to the lifting bail (hook) of the equipment.
- **NEVER** lift the equipment while the engine is running.
- Use adequate lifting cable (wire or rope) of sufficient strength.
- Use one point suspension hook and lift straight upwards.
- **NEVER** allow any person or animal to stand underneath the equipment while lifting.
- **DO NOT** lift machine to unnecessary heights.

TRANSPORTING



- **ALWAYS** shutdown engine before transporting.
- Tighten fuel tank cap securely and close fuel cock to prevent fuel from spilling.
- **ALWAYS** tie down the equipment during transport by securing the equipment with rope.

REFUELING

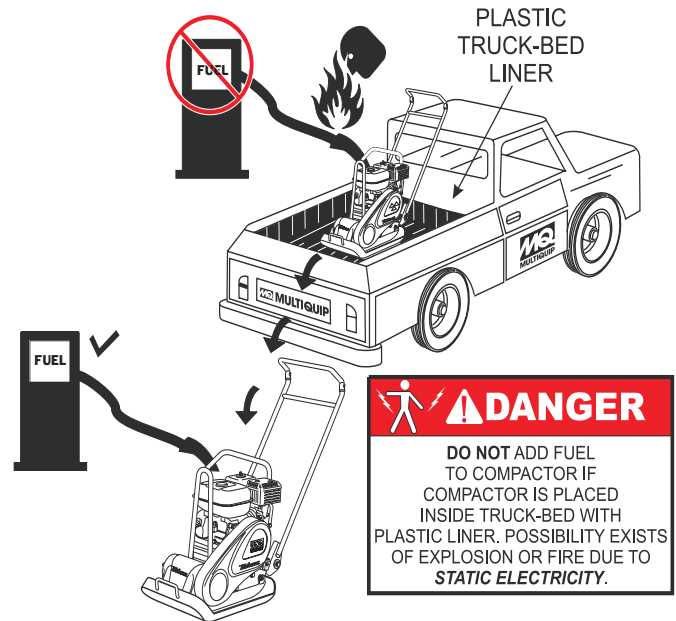

MAINTENANCE SAFETY

- **NEVER** lubricate components or attempt service on a running machine.
- **ALWAYS** allow the machine a proper amount of time to cool before servicing.
- Keep the equipment in proper running condition.
- Fix damage to the equipment immediately and always replace broken parts.
- Dispose of hazardous waste properly. Examples of potentially hazardous waste are used motor oil, fuel and fuel filters.
- **DO NOT** use food or plastic containers to dispose of hazardous waste.
- **DO NOT** pour waste, oil or fuel directly onto the ground, down a drain or into any water source.

RULES AND REGULATIONS

EMERGENCIES

- **ALWAYS** know the location of the nearest *fire extinguisher*.
- **ALWAYS** know the location of the nearest *first aid kit*.
- In emergencies, *always* know the location of the nearest phone or **keep a phone on the job site**. Also know the phone numbers of the nearest **ambulance**, **doctor** and **fire department**. This information will be invaluable in case of emergency.



BATTERY SAFETY (FOR ELECTRIC START)

- The battery contains acids that can cause injury to the eyes and skin. **ALWAYS** wear safety glasses to avoid eye irritation.
- **ALWAYS** wear well-insulated gloves when picking up the battery.
- **ALWAYS** keep the battery charged. If the battery is not charged, a buildup of combustible gas will occur.
- **DO NOT** charge battery if frozen. Battery can explode. When frozen, warm the battery to at least 61° F (16° C).
- **ALWAYS** make sure battery terminals are properly connected. Inadequate battery connections may cause poor starting of the equipment and create other malfunctions.
- **ALWAYS** keep battery cables in good working condition. Repair or replace all worn cables.
- **ALWAYS** recharge the battery in a vented air environment, to avoid risk of a dangerous concentration of combustible gases.
- **ALWAYS** disconnect the negative battery terminal before performing service on the equipment.
- If the battery liquid (dilute sulfuric acid) comes in contact with clothing or skin, rinse skin or clothing immediately with plenty of water.
- If the battery liquid (dilute sulfuric acid) comes in contact with your **EYES**, rinse eyes immediately with plenty of water and contact the nearest doctor or hospital to seek medical attention.



DANGER — Explosion Hazards

The risk of an explosion exists when performing service on the battery. To avoid **severe injury** or **DEATH**:



DO NOT drop the battery. There is the possibility of risk that the battery may explode.

DO NOT expose the battery to open flames, sparks, cigarettes, etc. The battery contains combustible gases and liquids. If these gases and liquids come in contact with a flame or spark, an explosion could occur.

SPECIFICATIONS

Table 1. MVH-206D Specifications

Centrifugal Force	7,870 lbf (35 kN)
Vibration Frequency	5,200 vpm (86.7 Hz)
Traveling Speed	0 to 75 ft/min (0 to 23 m/min)
Plate Size (L x W)	28.4 x 19.7 in (720 x 500 mm)
Max. Area of Compaction	7,380 sq. ft./h (690 sq. meters/h)
Operating Weight	494 lbs (224 kg)
Vibrating Oil Capacity	0.63 quart (0.6 liter)

Table 2. Engine Specifications

Model	YANMAR L70V6GF1R1AA
Type	Air-cooled, 4-cycle Diesel Engine
Bore X Stroke	3.07 in. X 2.64 in. (78 mm x 67 mm.)
Displacement	19.5 cu. in. (320 cc)
Max Power Output	6.4 HP (4.8 KW) @ 3600 R.P.M.
Fuel Tank Capacity	3.5 quarts (3.3 liters)
Fuel	Unleaded Automobile Gasoline
Operating Speed	3,200 rpm
Lube Oil Capacity	1.2 quarts (1.1 liters)
Speed Control Method	Centrifugal Flyweight Type
Starting Method	Recoil Start

DIMENSIONS

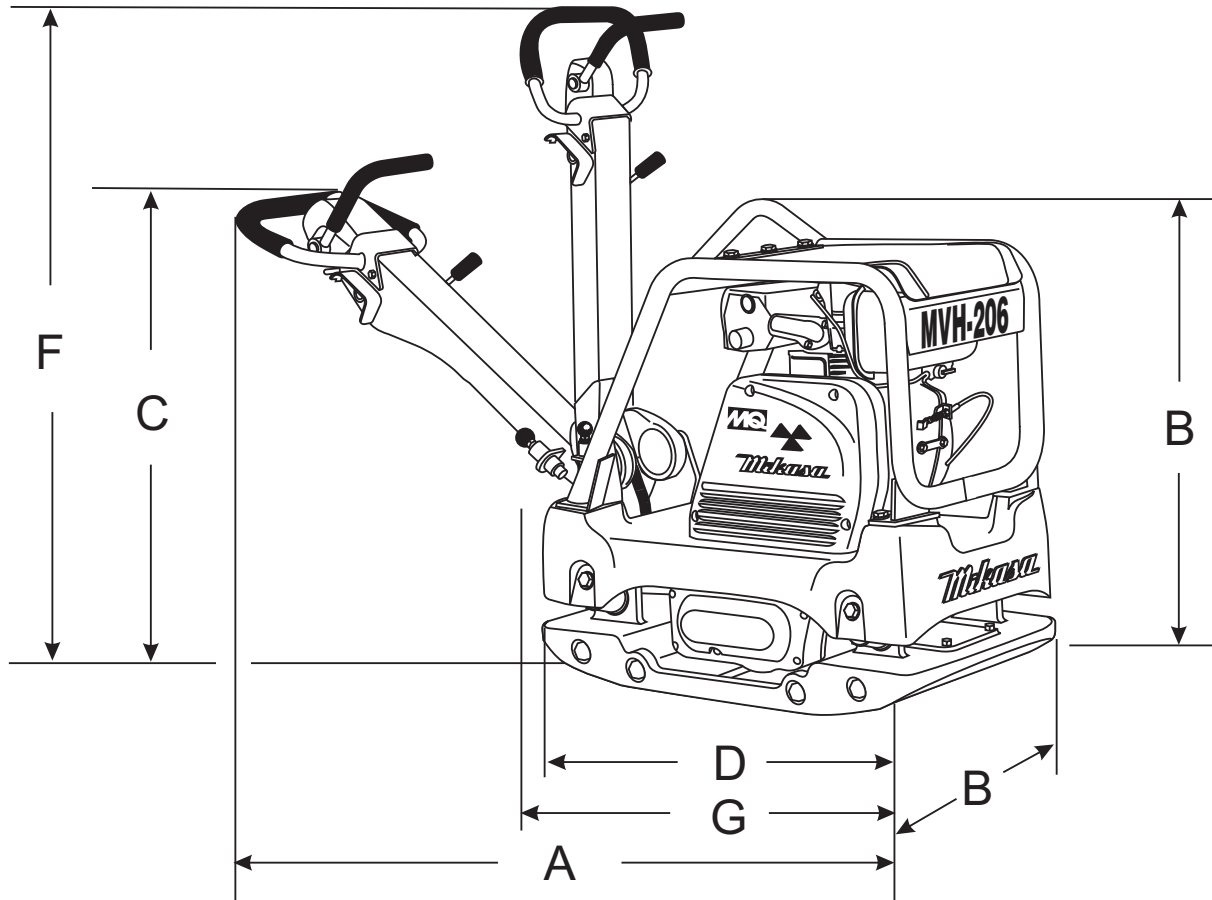

Figure 1. MVH206D Dimensions

Table 3. Dimensions		
Reference	Description	Measurement
A	Length (Handle in Working Position)	54.3 in (1,380 mm)
B	Height of Main Body	30 in (763 mm)
C	Height (Handle in Working Position)	34 in (1,100mm)
D	Lenght of Plate	28.4 in (720 mm)
E	Width of Plate	19.7 in (500 mm)
F	Height (Handle in Vertical Position)	51.6 in (1,310 mm)
G	Length (Handle in Vertical Position)	31.5 in (800 mm)

PLATE COMPACTOR

The Mikasa MVH-206D is a walk behind, reversible plate compactor designed for the compaction of sand, clay and asphalt. This plate compactor is a powerful compacting tool capable of applying a tremendous force in consecutive high frequency vibrations to a soil surface. Its applications include soil compacting for road, embankments and reservoirs as well as backfilling for gas pipelines, water pipelines and cable installation work.

VIBRATORY PLATES

The vibratory plates of the MVH-206D produce low amplitude high frequency vibrations, designed to compact granular soils.

The resulting vibrations cause forward motion. The engine and handle are vibration isolated from the vibrating plate. The heavier the plate, the more compaction force it generates.

REVERSIBLE VIBRATORY PLATES

Reversible vibratory plates have two eccentric weights that allow a smooth transition for forward and reverse travel, plus increased compaction force as the result of dual weights.

Due to their weight and force, reversible plates are ideal for semi-cohesive soils.

FREQUENCY/SPEED

The compactor's vibrating plate maximum frequency is 5200 vpm (vibrations per minute). The forward and reverse travel speed of the compactor is approximately 75 feet/minute (23 meters/minute).

ENGINE

The Mikasa MVH-206D Plate Compactor is equipped with a Yanmar L70V6GF1R1AA (recoil start) diesel engine.

CONTROLS

Before starting the MVH-206D Plate Compactor, identify and understand the function of the controls and components.

CONTROLS AND COMPONENTS

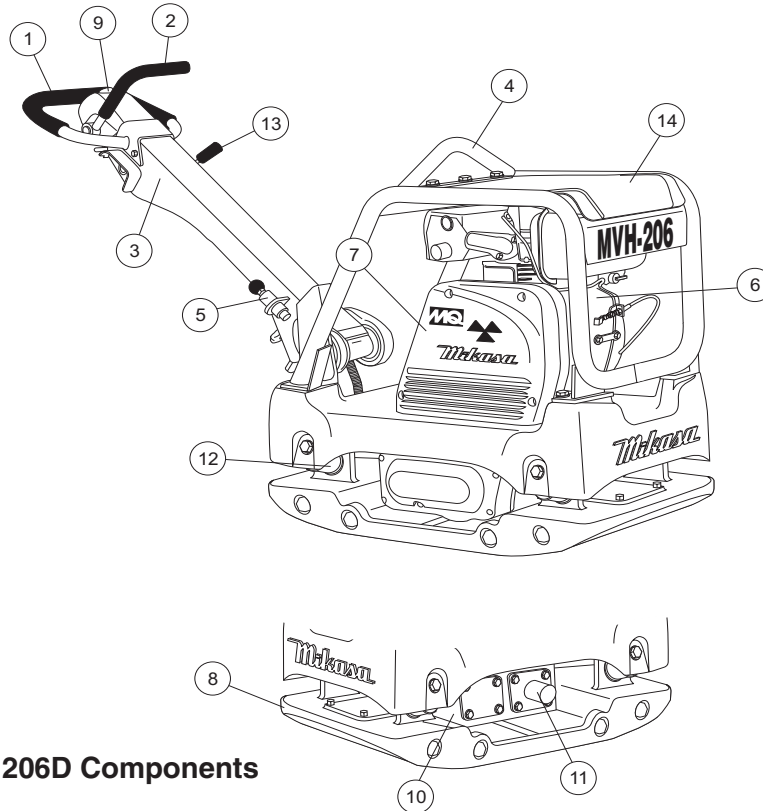

Figure 2. MVH206D Components

Figure 2 illustrates the location of the major components for the MVH-206D Reversible Plate Compactor. The function of each component is described below:

1. **Hand Grip** – When operating the compactor use this hand grip to maneuver the compactor.
2. **Forward and Reverse Lever** – **Push** the lever forward, the compactor will move in a forward direction. **Pull** the lever backwards, the compactor will move in reverse direction. Placing the lever in the middle (midway) will cause the compactor not to move (neutral).
3. **Handle Bar** – When operating the compactor, this handle should be in the downward position. When the compactor is to be **stored**, move the handle bar to the upright position.
4. **Guard Hook** - Used to lift the machine with a crane or other lifting device.
5. **Stopper** - Locks the handle in place in the upward position for stowing.
6. **Engine** – This plate compactor uses a **YANMAR L70V6GF1R1AA** diesel engine. Refer to the engine owner's manual for engine information.
7. **Belt Cover** – Remove this cover to gain access to the V-belts. **NEVER** run the compactor without the V-belt cover. If the V-belt cover is not installed, the possibility exists of your hand getting caught between the V-belt and clutch, thus causing serious injury and bodily harm.
8. **Base Plate** – Designed to compact sand, clay, and asphalt.
9. **Oil Reservoir** – Fill with Shell Tellus Oil 46 or equivalent grade hydraulic oil.
10. **Vibration Case** – Encloses the eccentric, gears and counter weights.
11. **Hydraulic Cylinder** – Activated by moving the travel lever. The cylinder controls the direction of movement by the plate compactor.
12. **Shock Absorber** – Protects plate compactor from damage by absorbing vibration during operation.
13. **Throttle Lever** – Controls speed of the plate compactor. Place straight vertically to start, **push** fully counterclockwise for full throttle and fully clockwise to stop plate compactor.
14. **Rubber Cover** – Lift this rubber cover to gain access to the fuel tank.

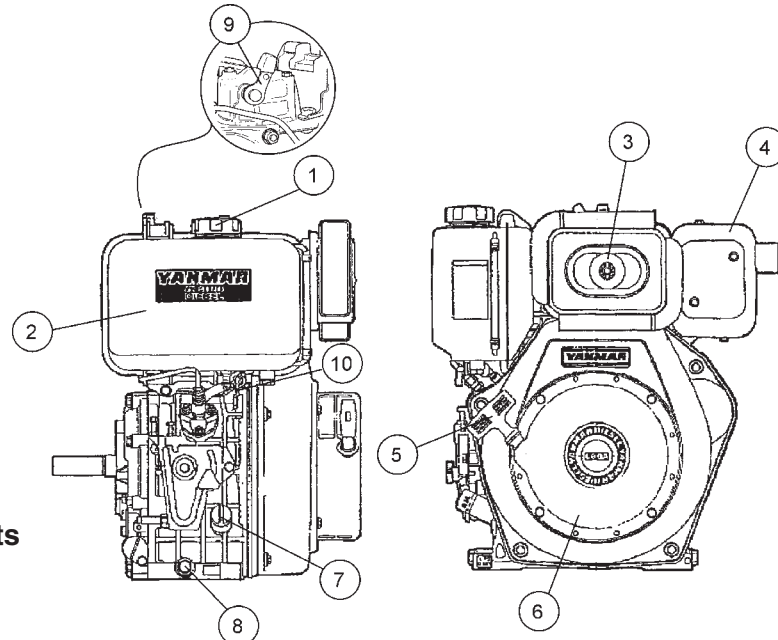



Figure 3. YANMAR Engine Components

The engine shown above is a **YANMAR** engine (Figure 3). It must be checked for proper lubrication and filled with fuel prior to operation. Refer to the engine manual for operation and servicing information.

1. **Fuel Filler Cap** – Remove this cap to add unleaded gasoline to the fuel tank. Make sure cap is tightened securely. **DO NOT** over fill.
2. **Fuel Tank** – Holds 3.5 quarts (3.3 liters) of diesel fuel. For additional information refer to engine owner's manual.

⚠ DANGER — Fuel Hazard



Adding fuel to the tank should be done only when the engine is stopped and has had an opportunity to cool down. In the event of a fuel spill, **DO NOT** attempt to start the engine until the fuel residue has been completely wiped up and the area surrounding the engine is dry.

3. **Air Cleaner** – Prevents dirt and other debris from entering the fuel system. Remove wing-nut on top of air filter cannister to gain access to filter element.

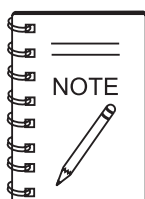

Operating the engine without an air filter, with a damaged air filter, or a filter in need of replacement will allow dirt to enter the engine, causing rapid engine wear.

4. **Muffler** – Used to reduce noise and emissions.
5. **Recoil Starting Handle (pull rope)** – For manual starting method, pull the starter grip until resistance is felt, then pull briskly and smoothly.
6. **Recoil Starter** – Used for manual-starting method.
7. **Oil Filler Cap/Dipstick** – Remove this cap to add oil to the engine crankcase. Read dipstick to determine if oil level is low. Do not overfill.
8. **Oil Drain Plug** – Unscrew plug to drain oil from the engine crankcase. Dispose of oil in a safe manner.
9. **Decompression Lever** – Press down before starting engine. To prevent damage to engine, do not use for any other purpose.
10. **Fuel Cock** – controls the flow of diesel fuel to the carburetor. Must be in the ON position when starting and running the engine.

⚠ WARNING — Hot Components



Engine components can generate extreme heat. To prevent burns, **DO NOT** touch these areas while the engine is running or immediately after operating. **NEVER** operate the engine with the muffler removed.

⚠ CAUTION — Eye and Hearing Hazards



ALWAYS wear approved eye and hearing protection when required.

⚠ WARNING — Lethal Gas Exhaust Hazard



NEVER operate the compactor in a confined area or enclosed area structure that does not provide ample *free flow of air*.

Before Starting

1. Read safety instructions at the beginning of manual.
2. Familiarize yourself with the operating and control elements of the machine and the working environment. This includes obstacles in the working area, bearing capacity of the ground and the necessary safety provisions. 
3. Check the air filter for dirt and dust. If air filter is dirty, replace air filter with a new one as required.
4. Check fastening nuts and bolts for tightness. Loose threads may cause damage to the machine when vibrating.
5. Understand the geographical features and regulations of the job site.
6. Clean the compactor, removing dirt and dust. Particularly, the bottom of the plate, engine cooling air inlet.

Checking Engine Oil Level

1. To check the engine oil level, place the compactor on secure level ground with the engine stopped.
2. Remove the dipstick from the engine oil filler hole (Figure 4) and wipe it clean.
3. Insert and remove the dipstick without screwing it into the filler neck. Check the oil level shown on the dipstick.
4. If the oil level is low (Figure 5), fill to the edge of the oil filler hole with the recommended oil type (Table 4).

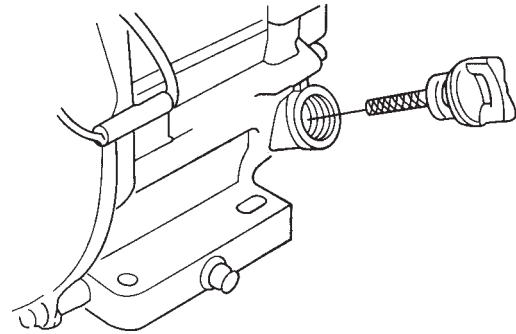

Figure 4. Engine Oil Dipstick Removal

Maximum oil capacity is 1.2 quarts (1.10 liters).

Checking the Hydraulic Oil Level

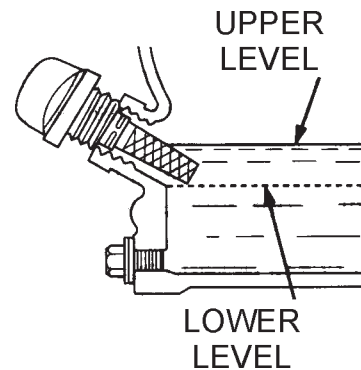

Figure 5. Engine Oil Level

Table 4. Oil Type

Season	Temperature	Oil Type
Summer	25°C or Higher	SAE 10W-30
Spring/Fall	25°C~10°C	SAE 10W-30/20
Winter	0°C or Lower	SAE 10W-10

1. To check the engine oil level, place the compactor on secure level ground with the engine stopped.
2. Remove the hydraulic oil breather cap located at the top of the hydraulic oil tank (Figure 6).
3. Using a 24 mm wrench, remove the hydraulic oil filler plug.

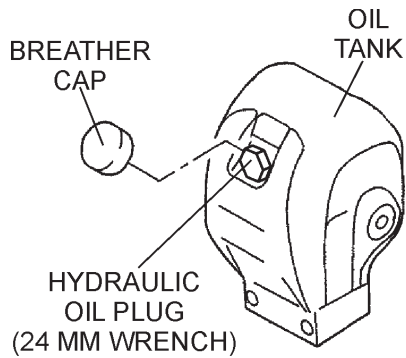

Figure 6. Hydraulic Oil Filler Plug Removal

4. Visually inspect to determine if hydraulic oil level is low. If oil level is low add Shell Tellus 46 hydraulic oil or equivalent through the hand pump oil filler port.

CAUTION — Oil Leaks

DO NOT overfill hydraulic oil tank. This could cause oil leaks and sluggish operation. Clean cap and surrounding area before opening to prevent dirt from entering oil tank.

5. When adding hydraulic oil, only fill to the specified oil level as marked on the front of the hydraulic oil tank (Figure 7). **DO NOT** overfill.



Figure 7. Oil Tank (Front View)

Checking the Air Cleaner

1. Loosen the wing nut and remove the air cleaner cover as shown in Figure 8.
2. Remove the air cleaner element and inspect it for signs of wear or dirt. If air cleaner element is dirty, clean or replace element.

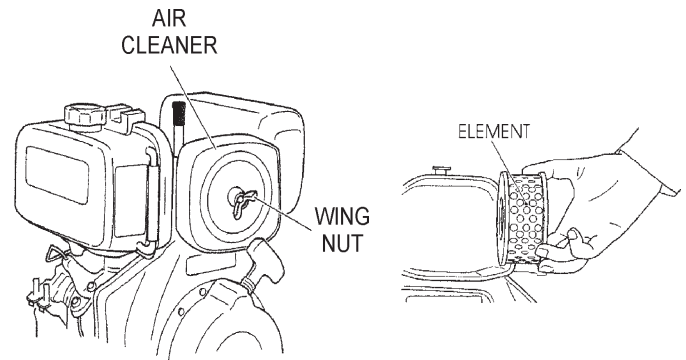

Figure 8. Air Cleaner Element

Checking The Fuel

1. Remove the fuel cap located on top of fuel tank.
2. Visually inspect to see if fuel level is low. If fuel is low, replenish with unleaded gasoline. (Figure 9).
3. When refueling, be sure to use a strainer for filtration. **DO NOT** top-off fuel. Wipe up any spilled fuel.

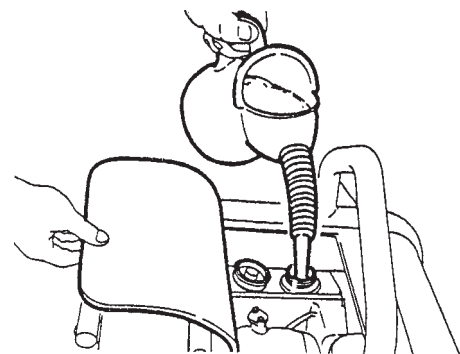

Figure 9. Refueling

DANGER — Fuel Hazard



Adding fuel to the tank should be done only when the engine is stopped and has had an opportunity to cool down. In the event of a fuel spill, **DO NOT** attempt to start the engine until the fuel residue has been completely wiped up and the area surrounding the engine is dry.

RELEASING THE HANDLE

1. Pull the handle release pin, (Figure 10) then push down on the hand grip to release the handle.

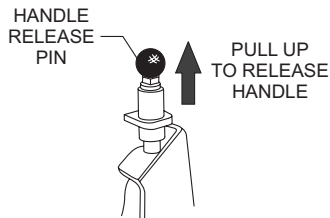
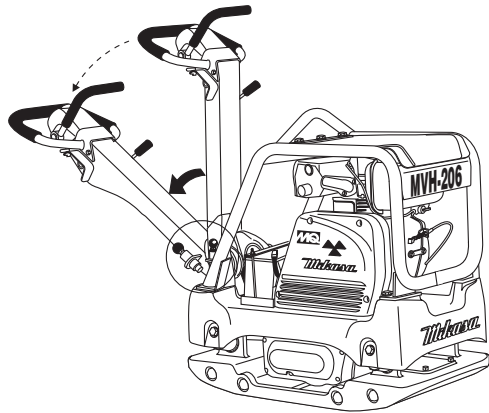

Figure 10. Handle Release Pin

ADJUSTING HANDLE HEIGHT

The height of the handle is adjustable for your comfort.

1. Loosen the butterfly screw (Figure 11).

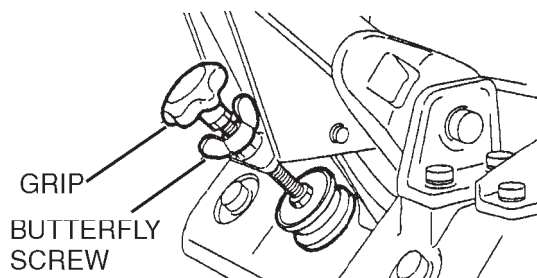

Figure 11. Handle Adjustment

2. Turn the grip clockwise to raise the handle or counterclockwise to lower the handle.
3. When the handle is raised to the desired height, tighten the butterfly screw.

STARTING THE ENGINE

1. Open the fuel cock (Figure 12).

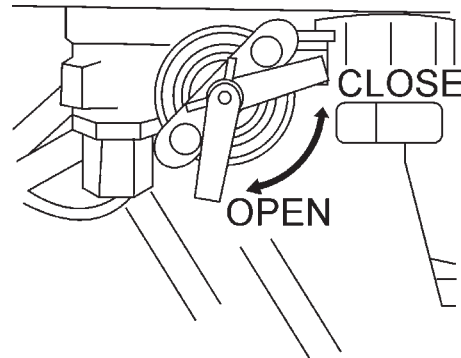

Figure 12. Fuel Cock

2. Move the throttle lever to the **START** position (Figure 13).

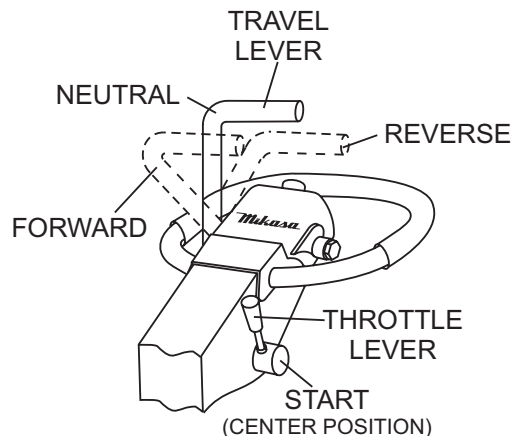

Figure 13. Throttle Lever (START)

3. Grasp the starter grip (Figure 14) and slowly pull it out. The resistance becomes the hardest at a certain position, corresponding to the compression point. Pull the starter grip briskly and smoothly for starting.

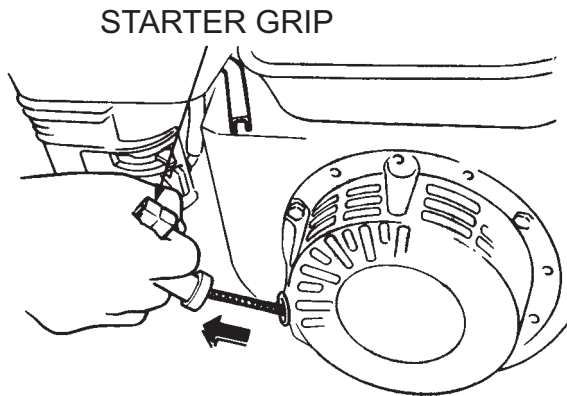

Figure 14. Starter Grip

4. Push the decompression lever (Figure 15) and release.

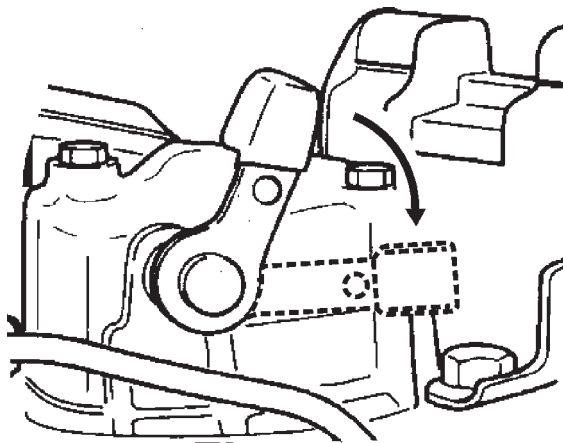

Figure 15. Decompression Lever

TRAVELING

1. Grasp the compactor's hand grip (Figure 16), and move the engine throttle lever quickly to the **fast** position.

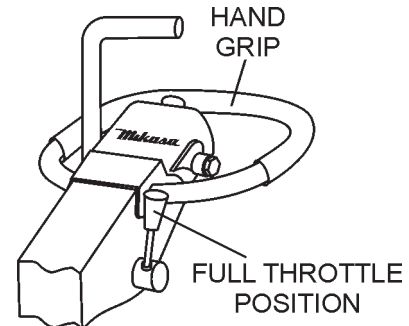

Figure 16. Throttle Lever (FAST)

2. With the throttle lever in the fast position, the engine speed should be around 3,600 RPM, therefore engaging the centrifugal clutch.



ALWAYS move the throttle lever quickly without hesitation, because increasing the engine speed slowly causes the clutch to slip.

3. To make the compactor move in the forward direction push the travel lever (Figure 17) forward.

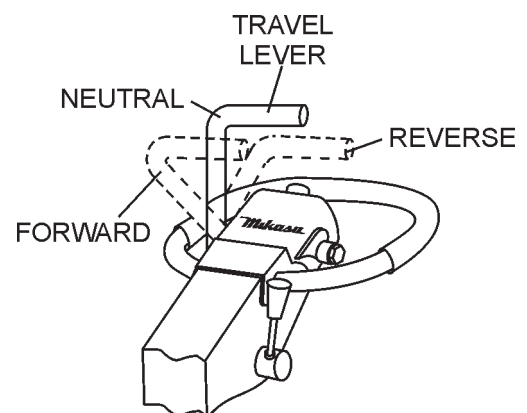

Figure 17. Travel Lever

4. To make the compactor move in the reverse direction pull the travel lever (Figure 17) backwards.

OPERATION

5. Firmly grasp the compactor's hand grip, the compactor will begin moving in the desired position when the direction lever has been placed in the desired position.
6. Slowly walk behind the compactor and be on the lookout for any large objects or foreign matter that might cause damage to the compactor or bodily injury.
7. If travel lever is placed in the neutral position, the machine will vibrate in place.
8. To move the compactor laterally, hold the hand grip firmly and swing compactor. **DO NOT** swing compactor while gripping the travel lever.

NORMAL SHUTDOWN

1. Return the throttle lever to the **START** position (Figure 13). Allow the machine to cool down for 2 to 3 minutes.

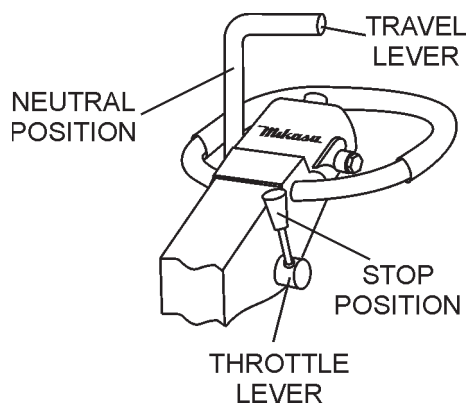

Figure 18. Travel Lever (STOP)

2. Place the travel lever in the **NEUTRAL** position.
3. Place the throttle lever in the **STOP** position (Figure 18) to stop the engine.
4. Close the fuel cock (Figure 12).

EMERGENCY SHUTDOWN

1. For a recoil start type engine, move the throttle lever quickly to the **STOP** position.

STOWING THE HANDLE

1. Push up the handle upward (Figure 19) until the handle locks in place.

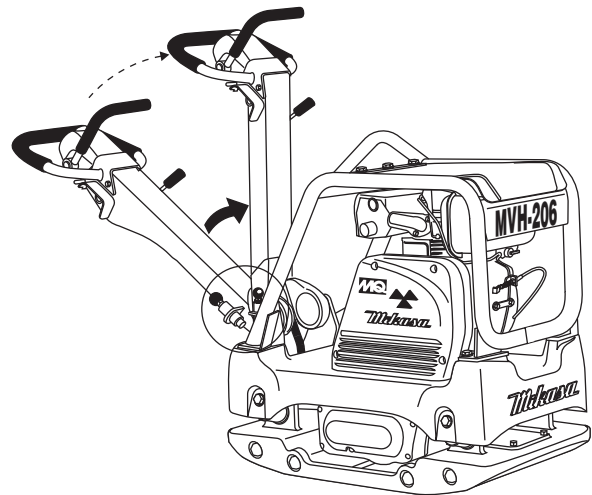

Figure 19. Stowing the Handle

⚠ CAUTION — Inspection Requirements

Inspection and other services should *always* be carried out on hard and level ground with the engine shutdown.

INSPECTION

To make sure your compactor is always in good working condition, perform maintenance inspection in accordance with Tables 5 through 7 before use.

Table 5. MVH-206D Inspection

ITEM	HOURS OF OPERATION
Loose or Missing Screws	Every 8 hours (every day)
Damaged Parts	Every 8 hours (every day)
Function of Controlling System Part	Every 8 hours (every day)
Hydraulic System Leak	Every 100 hours
Vibrator Oil Check	Every 100 hours
Vibrator Oil Replacement	Every 300 hours
Hydraulic Oil Check	Every 100 hours
Hydraulic Oil Replacement	First after 200 hours, then every 1,000 hours
V-belt (clutch) Check	Every 200 hours

⚠ CAUTION — Inspection Intervals

These inspection intervals are for operation under normal conditions. Adjust your inspection intervals based on the number hours plate compactor is in use, and particular working conditions.

⚠ CAUTION — Fuel Piping Replacement

Fuel piping and connections should be replaced every 2 years.

Table 6. MVH-206D Engine Check

Item	Hours of Operation
RPM Check	Every 40 hours (every week)
Oil or Fuel Leak	Every 8 hours (every day)
Tightness of Fastening Threads	Every 8 hours (every day)
Engine Oil Check and Replenishment	Every 8 hours (every day) (Replenish to specified maximum level)
Engine Oil Replacement	After first 25 hours then every 50 to 100 hours
Air Filter Cleaning	Every 100 hours
Engine Valve Adjustment	After first 50 hours then once a year and when required by poor performance thereafter.
See separate engine manual for details on engine check.	

DAILY SERVICE

- Check for leakage of fuel or oil.
- Check for loose screws including tightness. See Table 7 for retightening.

Table 7. Tightening Torque (kg cm)

Material	Diameter							
	6mm	8mm	10mm	12mm	14mm	16mm	18mm	20mm
4T	70	150	300	500	750	1,100	1,400	2,000
6-8T	100	250	500	800	1,300	2,000	2,700	3,800
11T	150	400	800	1,200	2,000	2,900	4,200	5,600
*	100	300~ 350	650 ~ 700					

* (In case counterpart is of aluminum)
(Threads in use with this machine are all right-handed)
Material and quality of material is marked on each bolt and screw.

- Remove soil and clean the bottom of compaction plate.
- Check hand pump, piping and hose for any leakage. A loosened hydraulic hose can be a cause for leakage. Check hydraulic hose connections with wrench applied for tightness.
- Check engine oil.

ENGINE OIL REPLACEMENT

1. Replace engine oil, first in 25 hours of operation and every 50 to 100 hours afterwards.
2. Drain the engine oil when the oil is **warm** as shown in Figure 20.

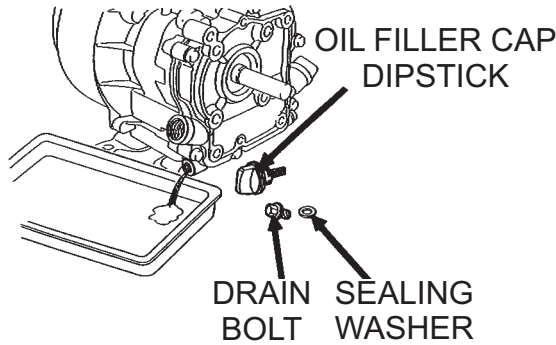

Figure 20. Engine Oil (Draining)

3. Remove the oil drain bolt and sealing washer and allow the oil to drain into a suitable container.
4. Replace engine oil with recommended type oil as listed in Table 4. Engine oil capacity is 1.16 quarts (1.1 liters). **DO NOT** overfill.
5. Install drain bolt with sealing washer and tighten securely.

AIR CLEANER

1. Remove the air cleaner cover and foam filter element as shown in Figure 21.

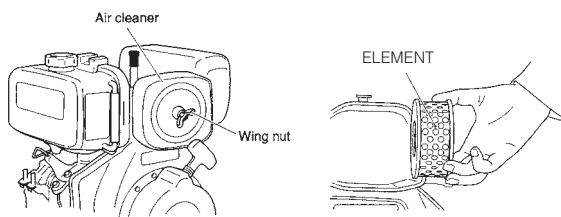

Figure 21. Engine Air Cleaner

3. Clean foam element in warm, soapy water or nonflammable solvent. Rinse and dry thoroughly. Dip the element in clean engine oil and completely squeeze out the excess oil from the element before installing.

! CAUTION — V-Belt Hazard

NEVER attempt to check the V-belt with the engine running. Severe injury can occur if your hand gets caught between the belt and clutch (Figure 22). Always wear safety gloves.

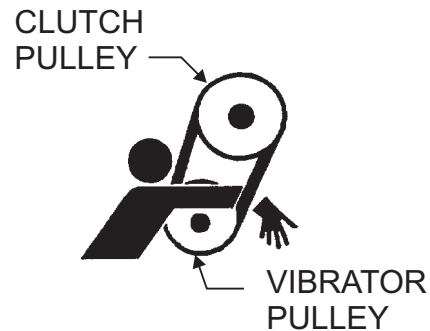

Figure 22. V-Belt Hazard

CHECKING AND REPLACING THE V-BELT AND CLUTCH

After 200 hours of operation, remove the belt cover to check the V-belt tension (Figure 23). Tension is proper if the belt bends about 3/8" (10 mm) when depressed strongly with finger between shafts. Loose or worn V-belts reduce power transmission efficiency, causing weak compaction and reduces the life of the belt itself.

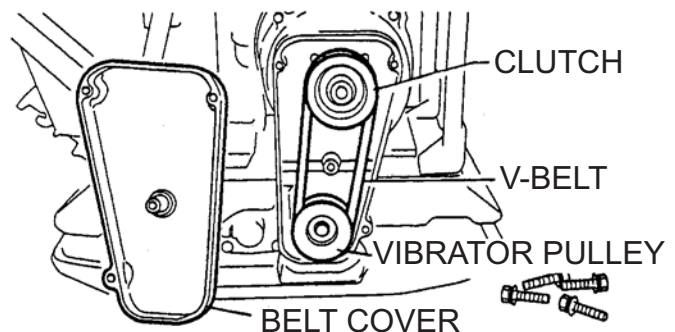

Figure 23. Engine Air Cleaner

Replacing the V-belt

Remove the belt cover. Engage an offset wrench 3/4" (19 mm) or the like to vibrator pulley (lower) fastening bolt. Engage waste cloth or the like at midway of V-belt on the left side and while pulling it back strongly, rotate the offset wrench clockwise so that the V-belt will come off.

Reinstalling the V-belt

Engage V-belt to lower vibrator pulley and push the V-belt to left side of upper clutch and, in the same manner as in removal, rotate offset wrench clockwise so that the V-belt goes back on.

Checking Clutch

Check the clutch simultaneously with V-belt checking. With belt cover removed, check outer drum of the clutch for seizure and "V" groove for wear or damage with your eyes. Clean the "V" groove as necessary. Wear of lining or shoe should be checked with running check. If the shoe is worn, power transmission becomes deficient and slipping will result.

Replacing Clutch

Remove V-belt. Remove bolt at engine power output by giving a shock to an engaged wrench (tapping with hammer or the like) and rotating bolt counterclockwise. Remove clutch with a pulley extractor. To reinstall, reverse the procedure.

CAUTION — Weak Vibration

Whenever the compactor's vibration becomes weak or lost during normal operation regardless of operation hours, check the V-belt and clutch immediately.

VIBRATOR OIL LEVEL CHECK

CAUTION — Dirt and Debris

Always clean the area around the vibrator oil level check plug before removing oil check plug. This will prevent dirt and debris from entering the system.

In every 100 hours of operation, with the machine positioned horizontally, use a 14 mm wrench and remove vibrator oil level check plug (Figure 24). Measure oil level with gauge. Vibrating oil capacity is 0.63 quart (0.6 liters). Be sure to clean area around check hole to prevent dirt and dust from entering.

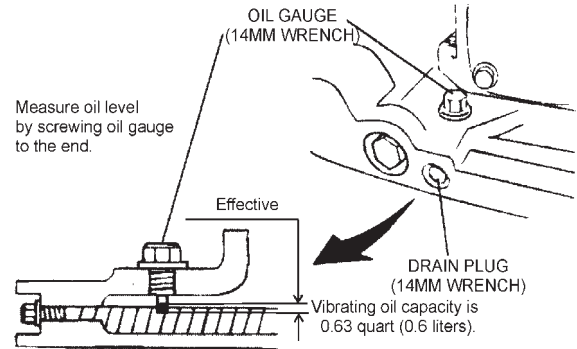
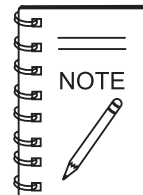

Figure 24. Vibrator Oil Drain and Check Plugs

DRAINING VIBRATOR OIL

1. Replace vibrator oil after first 200 hours and in every 1,000 hours of operation.
2. Position handle bar vertically (storage position).
3. Using a 14 mm wrench remove the vibrator oil drain plug (Figure 24) from the vibrating plate assembly.



For draining oil through level check hole, have the machine inclined with a sleeper or the like placed under the compaction plate on opposite side.

4. After vibrator oil has been completely drained from machine, fill with 10W-30 motor oil to the appropriate safe operating level (Figure 24).
5. Reinstall drain plug into vibrating plate assembly. Apply seal tape or Loctite #575 to thread portion of drain plug.

DRAINING HYDRAULIC OIL

1. Disconnect the hydraulic hose connected to the hydraulic oil cylinder (Figure 25).
2. Push the travel lever back and forth to drain the hydraulic oil from the hand pump (hydraulic oil reservoir).
3. After draining hydraulic oil, reconnect hydraulic oil hose to cylinder.
4. Place handle in upright position. Pull travel lever all the way back (reverse), and using a rope, secure travel lever to hand grip.

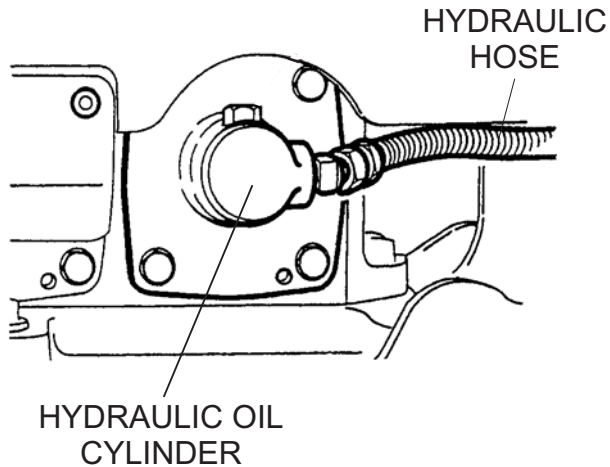

Figure 25. Hydraulic Oil Cylinder

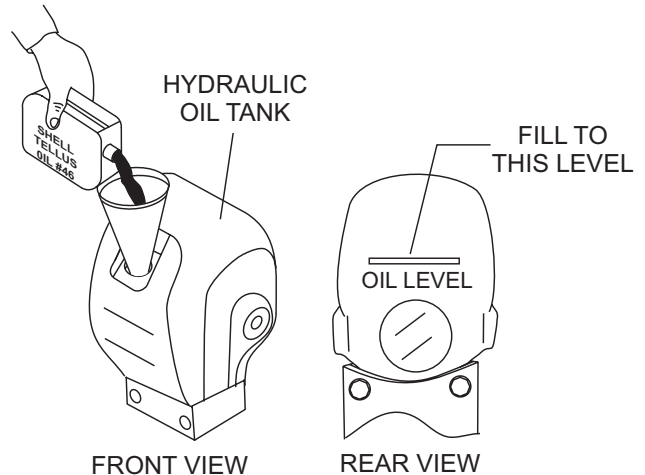

Figure 27. Hydraulic Oil Maintenance

ADDING HYDRAULIC OIL

1. Remove the breather cap and oil plug (Figure 26) from the hydraulic oil tank using a 24mm hex socket.

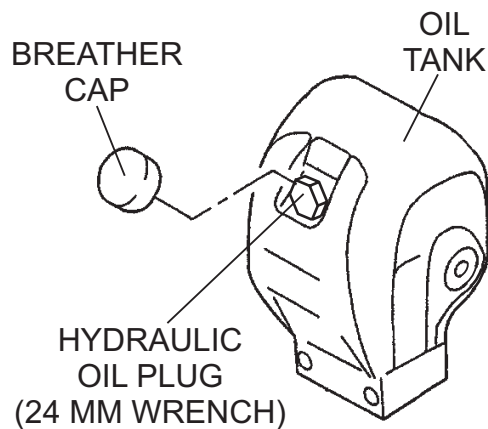

Figure 26. Hydraulic Oil Tank

2. Using a funnel, add **ShellTellus Oil #46** or equivalent to the hydraulic oil tank through the oil filler port (Figure 27). Oil tank capacity is 50.7 fl. oz (1500 cc).

⚠ CAUTION — Hydraulic Oil Overfill

Make sure hydraulic oil is at a normal safe operating level. **DO NOT** overfill. Overfilling (excessive oil) will cause excess oil to blow out of breather plug.

3. Loosen bleeder plug located at top of hydraulic cylinder on side of vibrator (Figure 28). Air remaining in the circuit will be forced out of the bleeder plug. Once all air has been purged from the hydraulic system, tighten bleeder plug securely.

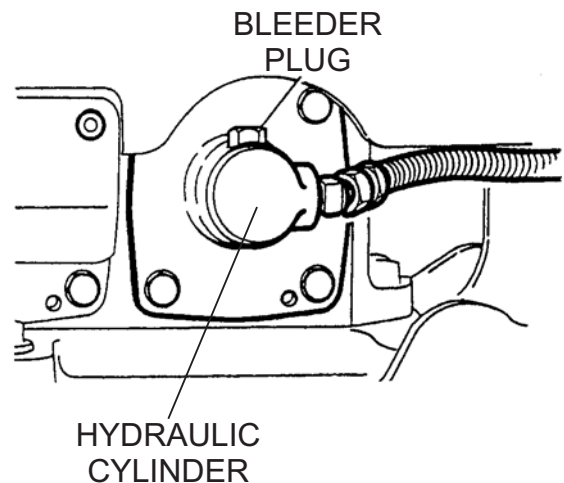

Figure 28. Bleeder Plug

4. Reinsert oil plug into hydraulic oil tank and tighten securely. Reinstall breather cap.

LONG TERM STORAGE

When storing your compactor for long periods do the following:

1. Run the engine at idle speed for 3-5 minutes.
2. Stop the engine. Drain the engine crankcase oil while the engine is still warm. Fill engine crankcase with fresh oil.
3. Wipe any oil or dirt that may have accumulated on the compactor.
4. Store compactor in a cool dry place out of reach of children and unauthorized personnel.

TROUBLESHOOTING

Practically all breakdowns can be prevented by proper handling and maintenance inspections, but in the event of a breakdown, please take remedial action based on the troubleshooting information shown. If the problem cannot be remedied, please leave the unit as is and consult Multiquip's business office or service plant.

TABLE 8. ENGINE TROUBLESHOOTING

SYMPTOM	POSSIBLE PROBLEM	SOLUTION
Engine will not start or start is delayed, although engine can be turned over.	Speed control lever is in "STOP" position?	Set speed control lever to "START" position.
	No fuel reaching injection pump?	Add fuel. Check entire fuel system.
	Defective fuel pump?	Replace fuel pump.
	Fuel filter clogged?	Replace fuel filter and clean tank.
	Faulty fuel supply line?	Replace or repair fuel line.
	Compression too low?	Check piston, cylinder and valves. Adjust or repair per engine repair manual.
	Fuel injector not working correctly?	Repair or replace injector in accordance with engine repair manual.
	Oil pressure too low?	Check engine oil pressure.
	Low starting temperature limit exceeded	Comply with cold starting instructions and proper oil viscosity.
At low temperatures engine will not start.	Fuel separates has inadequate resistance to low temperatures?	Check whether clear (not turbid) fuel emerges from the fuel line (detach from injection pump). If the fuel is turbid or separated, warm up the engine or drain the complete fuel supply system. Refuel with winter grade diesel fuel.
	Engine oil too thick?	Refill engine crankcase with correct type of oil for winter environment.
Engine fires but stops soon as starter is switched off.	Throttle lever in STOP position?	Reposition throttle lever to RUN position.
	Fuel filter blocked?	Replace fuel filter.
	Fuel supply blocked?	Check the entire fuel system.
Engine stops by itself during normal operation.	Fuel tank empty?	Add fuel.
	Fuel filter blocked?	Replace fuel filter.
Low engine power, output and speed.	Fuel tank empty?	Fill with No.2 diesel fuel.
	Fuel filter clogged?	Replace fuel filter.
	Fuel tank venting is inadequate?	Ensure that tank is adequately vented.
	Speed control lever does not remain in selected position?	See engine manual for corrective action.
	Engine oil level too full?	Correct engine oil level?
Low engine power output and low speed, black exhaust smoke.	Air filter blocked?	Clean or replace air filter.
	Incorrect valve clearances?	Adjust valves per engine specification.
	Malfuction at injector?	See engine manual.

Table 9. Compactor Troubleshooting

Symptom	Possible Cause	Solution
Travel speed low and vibration weak.	Clutch slips?	Adjust or replace clutch.
	V-belt slips?	Adjust or replace V-belt.
	Excessive Oil in vibrator?	Fill to correct level..
	Trouble in vibrator internals?	Check vibrator assembly for any worn or defective parts, replace any defective parts.
	Aeration in hydraulic oil for for travel reversing syste.?	Purge air in hydraulic oil. (Bleed plug)
	Engine speed incorrect?	Set engine speed to correct RPM.
Travels forward or backward but unable to switch direction.	Travel reversing system inoperative.?	Check entire travel system.
	Reversing lever installation correct?	Clean installation of reversing lever.
	Broken or defective oil hose?	Replace oil hose.
	Aeration in hydraulic oil for for travel reversing syste.?	Purge air in hydraulic oil. (Bleed plug)
	Excessive oil in reversing system?	Fill to correct level..
	Selector valve clogged with trash?	Clean selector valve.
	Cylinder piston bearing failure?	Check piston bearing in cylinder for leakage at USH packing.
Does not travel in forward or reverse.	V-belt dis-engaged or slips?	Engage V-belt, adjust or replace.
	Clutch slips?	Adjust clutch, replace if necessary.
	Pump input shat key or adapter key-way damaged?	Replace input shatkey or adapter key-way
	Cylinder piston bearing failure?	Check piston bearing in cylinder for leakage at USH packing.
Reversing lever operating resistance great.	Excessive hydraulic oil?	Fill to correct level.

EXPLANATION OF CODE IN REMARKS COLUMN

The following section explains the different symbols and remarks used in the Parts section of this manual. Use the help numbers found on the back page of the manual if there are any questions.

The contents and part numbers listed in the parts section are subject to change **without notice**. Multiquip does not guarantee the availability of the parts listed.

Sample Parts List:

<u>NO.</u>	<u>PART NO.</u>	<u>PART NAME</u>	<u>QTY.</u>	<u>REMARKS</u>
1	12345	BOLT	1	INCLUDES ITEMS W/*
2*		WASHER, 1/4 IN.		NOT SOLD SEPARATELY
2*	12347	WASHER, 3/8 IN. ... 1		MQ-45T ONLY
3	12348	HOSE	A/R	MAKE LOCALLY
4	12349	BEARING	1	S/N 2345B AND ABOVE

NO. Column

Unique Symbols - All items with same unique symbol (*, #, +, %, or >) in the number column belong to the same assembly or kit, which is indicated by a note in the "Remarks" column.

Duplicate Item Numbers - Duplicate numbers indicate multiple part numbers are in effect for the same general item, such as different size saw blade guards in use or a part that has been updated on newer versions of the same machine.



When ordering a part that has more than one item number listed, check the remarks column for help in determining the proper part to order.

PART NO. Column

Numbers Used - Part numbers can be indicated by a number, a blank entry, or TBD.

TBD (To Be Determined) is generally used to show a part that has not been assigned a formal part number at time of

QTY. Column

Numbers Used - Item quantity can be indicated by a number, a blank entry, or A/R.

A/R (As Required) is generally used for hoses or other parts that are sold in bulk and cut to length.

A blank entry generally indicates that the item is not sold separately. Other entries will be clarified in the "Remarks" Column.

REMARKS Column

Some of the most common notes found in the "Remarks" Column are listed below. Other additional notes needed to describe the item can also be shown.

Assembly/Kit - All items on the parts list with the same unique symbol will be included when this item is purchased.

Indicated by:

"INCLUDES ITEMS W/(unique symbol)"

Serial Number Break - Used to list an effective serial number range where a particular part is used.

Indicated by:

"S/N XXXXX AND BELOW"

"S/N XXXX AND ABOVE"

"S/N XXXX TO S/N XXX"

Specific Model Number Use - Indicates that the part is used only with the specific model number or model number variant listed. It can also be used to show a part is NOT used on a specific model or model number variant.

Indicated by:

"XXXXX ONLY"

"NOT USED ON XXXX"

"Make/Obtain Locally" - Indicates that the part can be purchased at any hardware shop or made out of available items. Examples include battery cables, shims, and certain washers and nuts.

"Not Sold Separately" - Indicates that an item cannot be purchased as a separate item and is either part of an assembly/kit that can be purchased, or is not available for

SUGGESTED SPARE PARTS







MVH206D W/ YANMAR L70V6GF1R1AA ENGINE

1 TO 3 Units

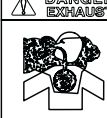
<u>QTY.</u>	<u>PART NO.</u>	<u>DESCRIPTION</u>
1	956100065	THROTTLE WIRE
2	070200363	V-BELT
3	11421012590	ELEMENT, AIR CLEANER
1	11428855041	CAP, FUEL TANK
1	11439976630	ROPE, STARTER
4	939010300	SHOCK ABSORBER

NAMEPLATE AND DECALS

10

 DANGER FUEL Fire risk	 DANGER EXHAUST Operate only in well-ventilated area
 DANGER LIFTING Do not stand next to machine while lifting	 DANGER LIFTING Do not use machine handle
 WARNING NOISE Wear ear protection	 WARNING HOT TEMP. Avoid contact with the muffler and cylinder
 CAUTION MOVING PARTS Do not touch moving parts in operation	 CAUTION READ Read operator's manual carefully before use

OPERATIONAL CAUTION

- Prior to OPERATION, check engine oil and fuel levels. If not enough, add to proper levels.
- Warm up engine at low speed for 3 to 5 minutes.
- Operate machine at full throttle speed. (Incorrect clutch engagement causes clutch to burn.)
- Use travel lever for forward & reverse motion. Do not push or pull travel lever strongly.

NPA-1317

12

OPERATIONAL CAUTION
Do not move travel lever if engine stops



NPA-1106

15



NPA-1169

3
Shell Tellus Oil 32

13

Operate Unit At Full Throttle
NPA-458

14



DCL333

25

V BELT HDPF-5360

21



5
MVH-206

20

Mikasa

Serial No.

Model No.

MQ MULTIQUIP

1

SAE 10W-30 MOTOR OIL
NPA-195

NAMEPLATE AND DECALS

<u>NO.</u>	<u>PART NO.</u>	<u>PART NAME</u>	<u>QTY.</u>	<u>REMARKS</u>
1	920201950	DECAL, OIL SAE 10W-30	1	NPA-195
3	920211090	DECAL, SHELL TELLUS OIL 32	1	
5	920111380	DECAL, MODEL LOGO	1	
10	920213170	DECAL, CAUTION	1	NPA-1317
12	920211060	DECAL, CAUTION (LEVER)	1	NPA-1106
13	920204580	DECAL, FULL THROTTLE	1	NPA-458
14	920203330	EAR PROTECTION LABEL	1	DCL333
15	920211690	DECAL, LEVER OPERATION	1	NPA-1169
20		PLATE, SERIAL NO.	1	CONTACT MQ PARTS DEPT.
21	920201580	DECAL, MQ MARK 71X55	1	
25	920205070	DECAL, V-BELT HDPF-5360	1	

VIBRATING PLATE ASSY

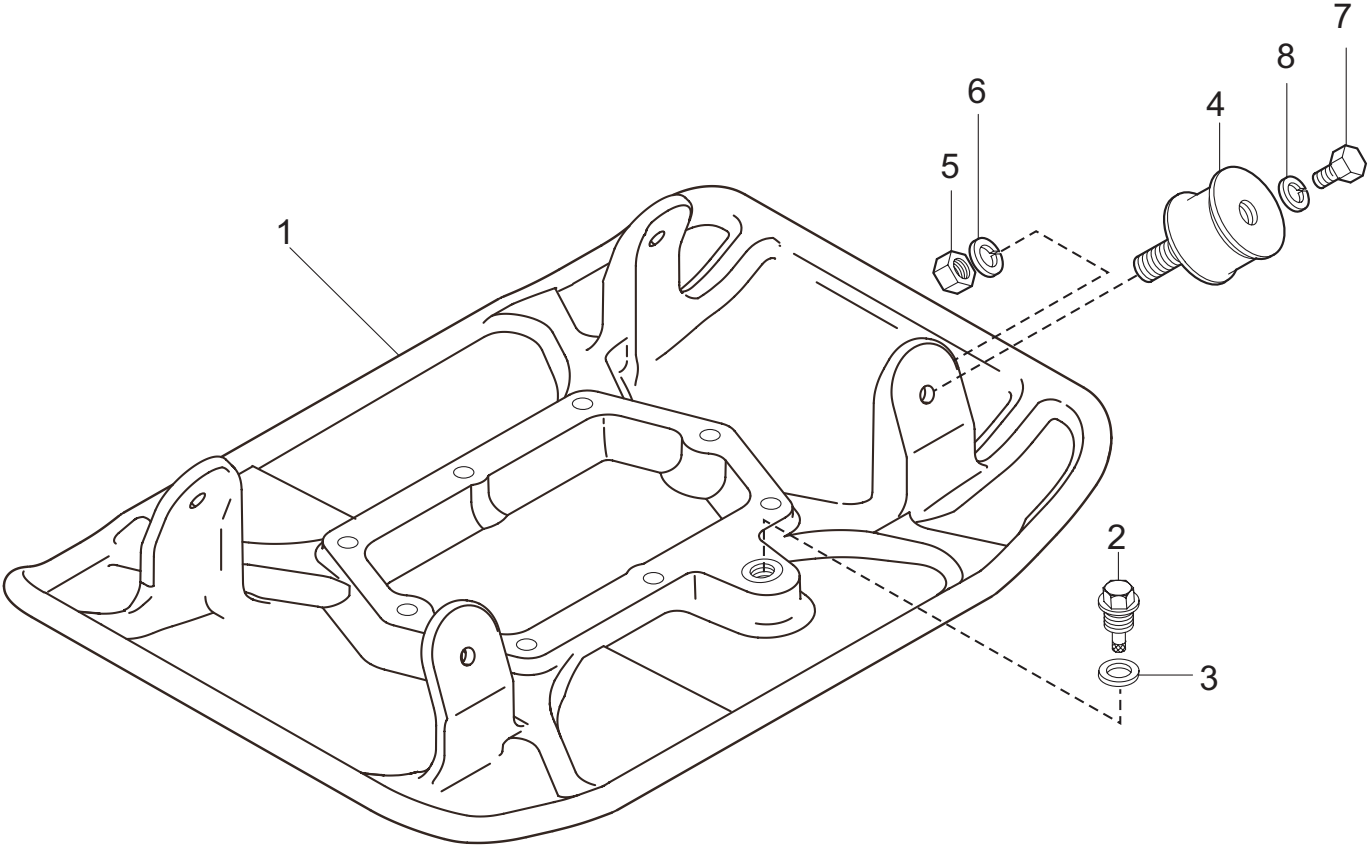

VIBRATING PLATE ASSY

<u>NO.</u>	<u>PART NO.</u>	<u>PART NAME</u>	<u>QTY.</u>	<u>REMARKS</u>
1	466119710	VIBRATING PLATE	1	
2	460449160	OIL GAUGE	1	
3	953405260	PACKING 1/4 (CU)	1	
4	939010300	SHOCK ABSORBER 75X50H	4	
5	020312100	NUT M12	4	
6	030212300	WASHER, LOCK M12	4	
7	001221235	BOLT 12X35 T	4	
8	030212300	WASHER, LOCK M12	4	

BASE AND ENGINE ASSY

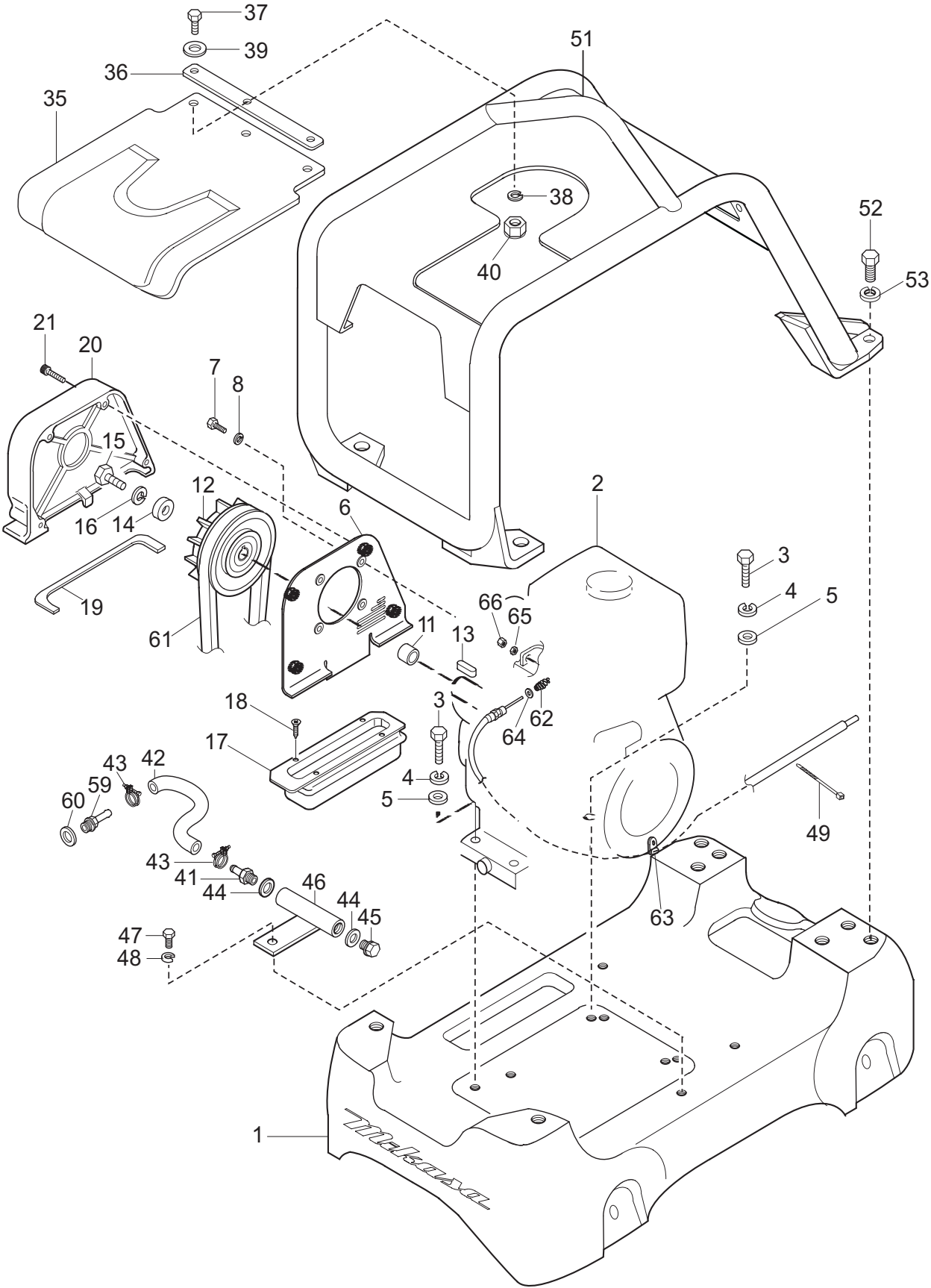

BASE AND ENGINE ASSY

<u>NO.</u>	<u>PART NO.</u>	<u>PART NAME</u>	<u>QTY.</u>	<u>REMARKS</u>
1	466119780	BASE	1	
2	914410029	ENGINE, L70V6GF1R1AA	1	
3	001221040	BOLT 10X40 T	4	
4	030210250	WASHER, LOCK M10	4	
5	031110160	WASHER, FLAT M10	4	
6	466347750	BELT COVER	1	
7	001220825	BOLT 8X25 T	4	
8	030208200	WASHER, LOCK M8	4	
11	466461470	SPACER	1	
12	466347700	CLUTCH ASSY/CHM03/W.FAN	1	
13	22512070360	KEY 7X36 RR	1	
14	466461490	WASHER, CLUTCH	1	
15	001220830	BOLT 8X30 T	1	
16	030208200	WASHER, LOCK M8	1	
17	466217870	DUST-PROOF COVER	1	
18	092006010	FLAT HEAD SCREW 6X10	4	
19	466347740	DUST-PROOF SPONGE (OUT)	1	
20	466119740	BELT COVER (OUT)	1	
21	001521054	SOCKET HEAD BOLT 10X70 T	4	
35	466119720	RUBBER COVER (GUARD FRAME)	1	
36	466461500	PLATE, COVER	1	
37	001220830	BOLT 8X30 T	3	
38	030208200	WASHER, LOCK M8	3	
39	031108160	WASHER, FLAT M8	3	
40	022710809	NYLON NUT M8	3	
41	2556390111	UNION	1	
42	2556380103	DRAIN HOSE	1	
43	0091720000	HOSE CLAMP	2	
44	0211140020	GASKET	2	
45	0401140030	PLUG	1	

BASE AND ENGINE ASSY

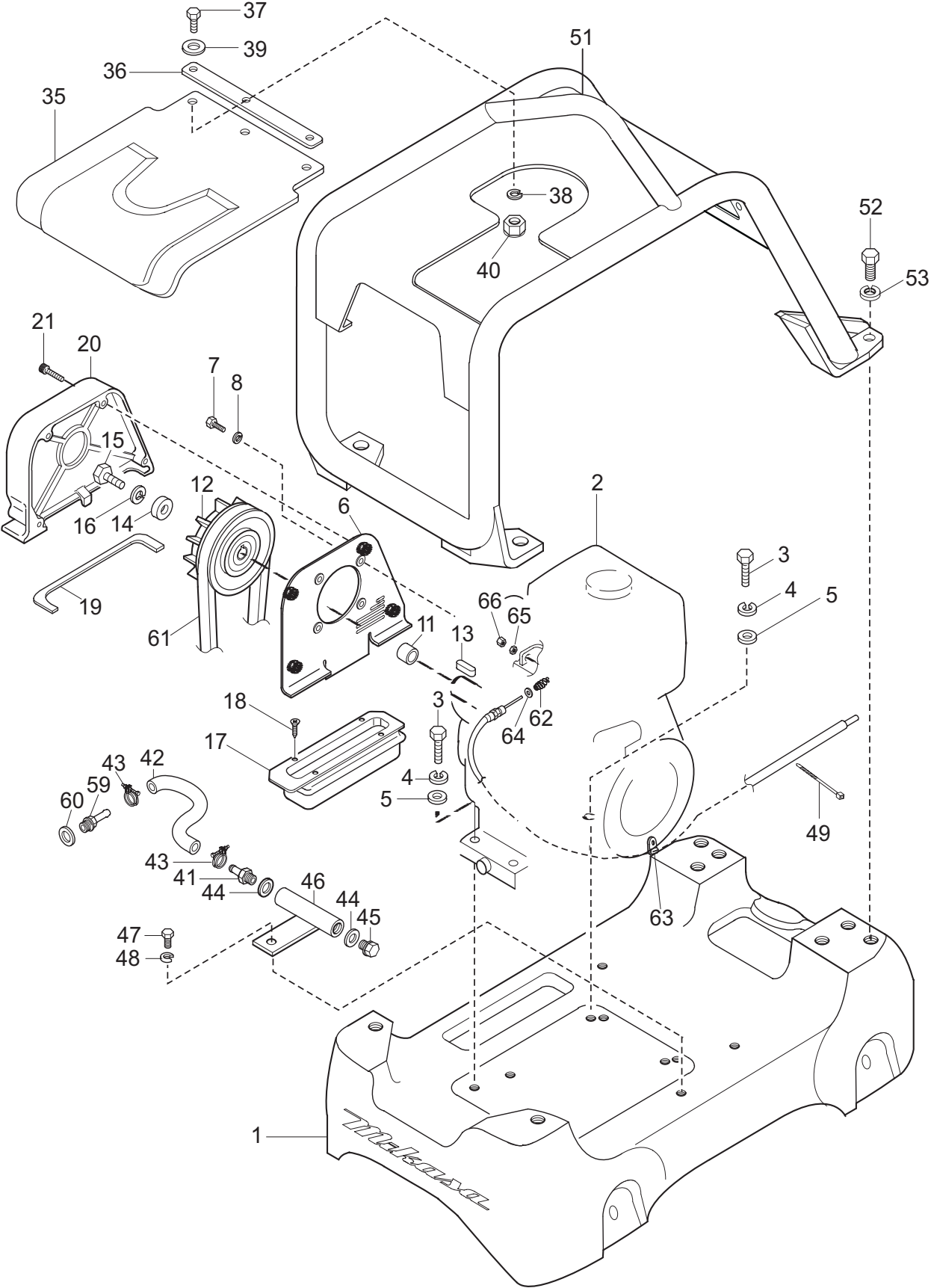

BASE AND ENGINE ASSY

<u>NO.</u>	<u>PART NO.</u>	<u>PART NAME</u>	<u>QTY.</u>	<u>REMARKS</u>
46	464457380	DRAIN JOINT	1	
47	001220820	BOLT 8X20 T	1	
48	030208200	SW M8	1	
49	454010020	CLAMP TC-100	1	
51	466119730	GUARD HOOK	1	
52	001221230	BOLT 12X30 T	4	
53	030212300	WASHER, LOCK M12	4	
59	459455560	JOINT, OIL DRAIN	1	
60	22190160002	WASHER, SEAL 16S	1	
61	070200363	V-BELT B-36 GREEN /HDPF536	1	
62	2344600213	RETURN SPRING	1	
63	2067550101	CLAMP COMPL	1	
64	031105080	WASHER, FLAT M5	1	
65	020406040	NUT M6, H = 4.2	1	
66	959406800	NUT M6 (SPECIAL - L10)	1	

VIBRATOR ASSY

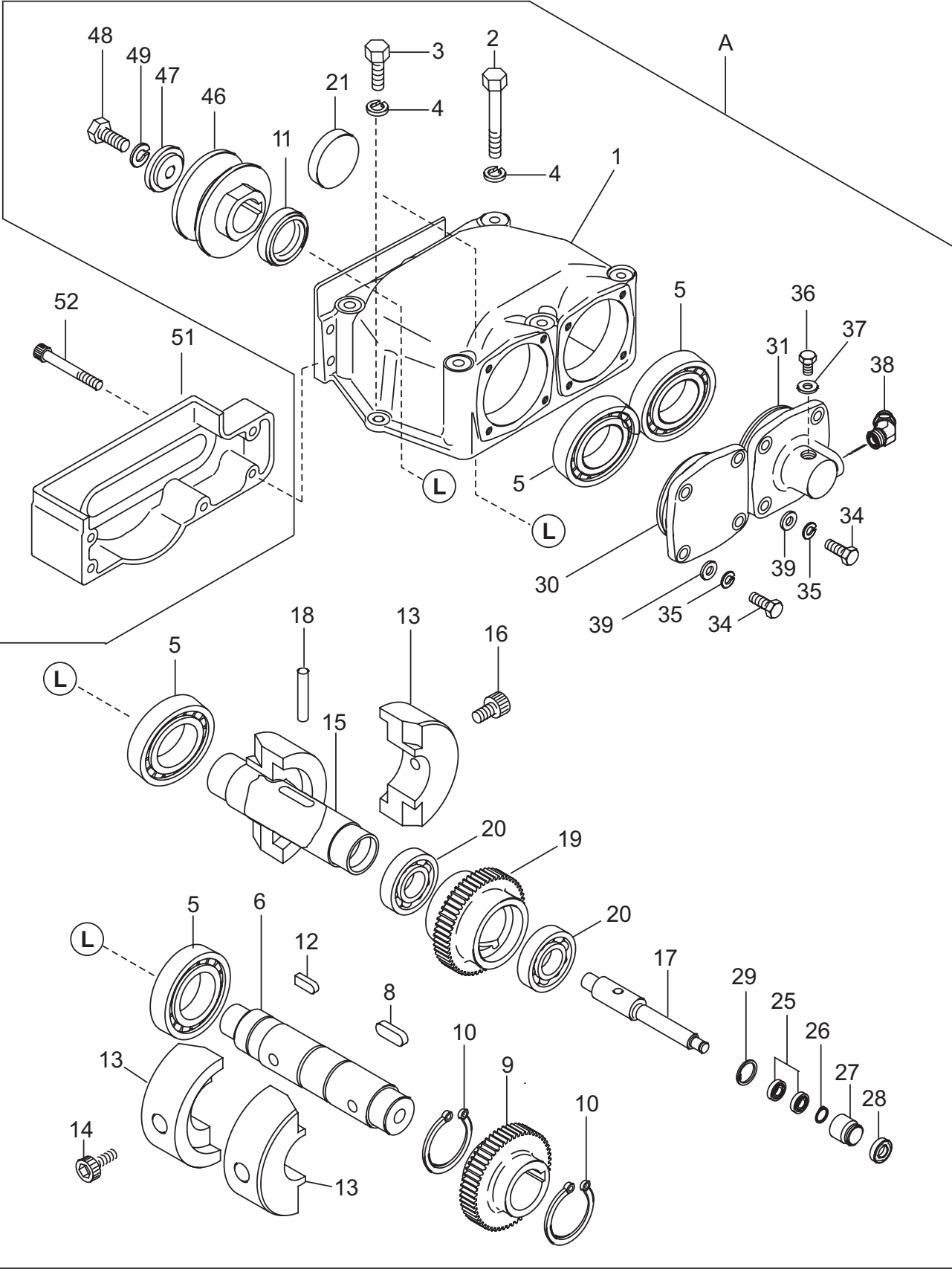

VIBRATOR ASSY

<u>NO.</u>	<u>PART NO.</u>	<u>PART NAME</u>	<u>QTY.</u>	<u>REMARKS</u>
A	466910010	VIBRATOR ASSY	1	INCLUDES ITEMS W/ #
1#	466119760	VIBRATING CASE	1	
2#	001221264	BOLT 12X120 T	6	
3#	001221235	BOLT 12X35 T	2	
4#	030212300	WASHER, LOCK M12	8	
5#	047920130	ROLLER BEARING NJ209EMC4	4	
6#	466347770	ROTARY SHAFT, DRIVE	1	
8#	951405370	KEY 15X10X39 RR	1	
9#	466347900	GEAR, DRIVE	1	
10#	080200500	STOP RING S-50	2	
11#	060104020	OIL SEAL SB-45689	1	
12#	951402300	KEY 10X8X27	1	
13#	466347780	ECCENTRIC ROTATOR	4	
14#	009120309	SOCKET HEAD BOLT 12X40T	2	
15#	466347790	ROTARY SHAFT, DRIVEN	1	
16#	009120308	SOCKET HEAD BOLT 12X25T	2	
17#	466347860	PISTON ROD	1	
18#	025510063	KNOCK PIN 10X63	1	
19#	466347800	GEAR (DRIVEN)	1	
20#	040006910	BEARING 6910	2	
21#	953010040	SEAL CAP/AC68-9	1	
25#	042506000	BEARING 6000ZZSG	2	
26#	080200100	STOP RING S-10	1	
27#	455435051	PISTON, 22.4D	1	
28#	455010070	PACKING USH-22.4X30X5	1	
29#	080100260	STOP RING R-26	1	
30#	466347810	BEARING COVER	1	
31#	466347820	CYLINDER (L)	1	
34#	001220825	BOLT 8X25 T	8	
35#	030208200	WASHER, LOCK M8	8	
36#	001220810	BOLT 8X10 T	1	
37#	953404600	COPPER PACKING 8X16X2	1	
38#	455010020	ELBOW 45° 15-0404	1	
39#	031108160	WASHER, FLAT M8	8	
46#	466347830	PULLEY	1	
47#	466461510	WASHER	1	
48#	001221230	BOLT 12X30 T	1	
49#	030212300	WASHER, LOCK M12	1	
51	466217880	BELT COVER (LOWER)	1	
52	001520855	SOCKET HEAD BOLT 8X75 T	5	

CONTROL ASSY

<u>NO.</u>	<u>PART NO.</u>	<u>PART NAME</u>	<u>QTY.</u>	<u>REMARKS</u>
A	362910060	THROTTLE LEVER ASSY	1	INCLUDES ITEMS W/ #
1	464343680	HANDLE BRACKET	1	
2	456336420	HANDLE BRACKET(R)	1	
3	001221235	BOLT 12X35 T	4	
4	030212300	WASHER, LOCK M12	4	
5	031112230	WASHER, FLAT M12	4	
7	456336400	RUBBER COUPLING	2	
8	456449940	SHOCK ABSORBER	2	
9	456449930	RUBBER PLATE	2	
10	001221681	BOLT 16X250 T	1	
11	032124400	CONICAL SPRING WASHER M24	2	
12	025406016	SPRING PIN 6X16	2	
13	031116260	WASHER, FLAT M16	2	
14	020316130	NUT M16	1	
15	020416100	NUT M16, H=10	1	
18	455434950	SPINDLE	1	
19	455010030	KNOB	1	
20	939010060	SHOCK ABSORBER	1	
21	020410060	NUT M10, H=6	1	
22	020412070	NUT M12, H=7	1	
23	022411635	WING NUT M16	1	
25	954404230	CLAMP SA120-18	1	
26	001220620	BOLT 6X20 T	1	
27	030206150	WASHER, LOCK M6	1	
28	031106100	WASHER, FLAT M6	1	
29	020306050	NUT M6	1	
34	501402870	HANDLE STOPPER	1	
35	501402880	SPRING/HANDLE (1.4X18X44)	1	
36	959403460	BALL GRIP 32D-M10	1	
37	020410060	NUT M10, H=6	1	
38	456449980	RUBBER PACKING 9D-20D-5T	1	
39	953405260	PACKING 1/4 (CU)	1	
40	031110160	WASHER, FLAT M10	1	
43	466217890	HANDLE COVER	1	
44	001220615	BOLT 6X15 T	6	
45	030206150	WASHER, LOCK M6	6	
46	031106100	WASHER, FLAT M6	6	
47	466462010	PACKING, HANDLE COVER	2	
61	466119770	HANDLE	1	
64	464216630	TRAVEL LEVER	1	
65	464457400	HANDLE BOSS	1	

CONTROL ASSY

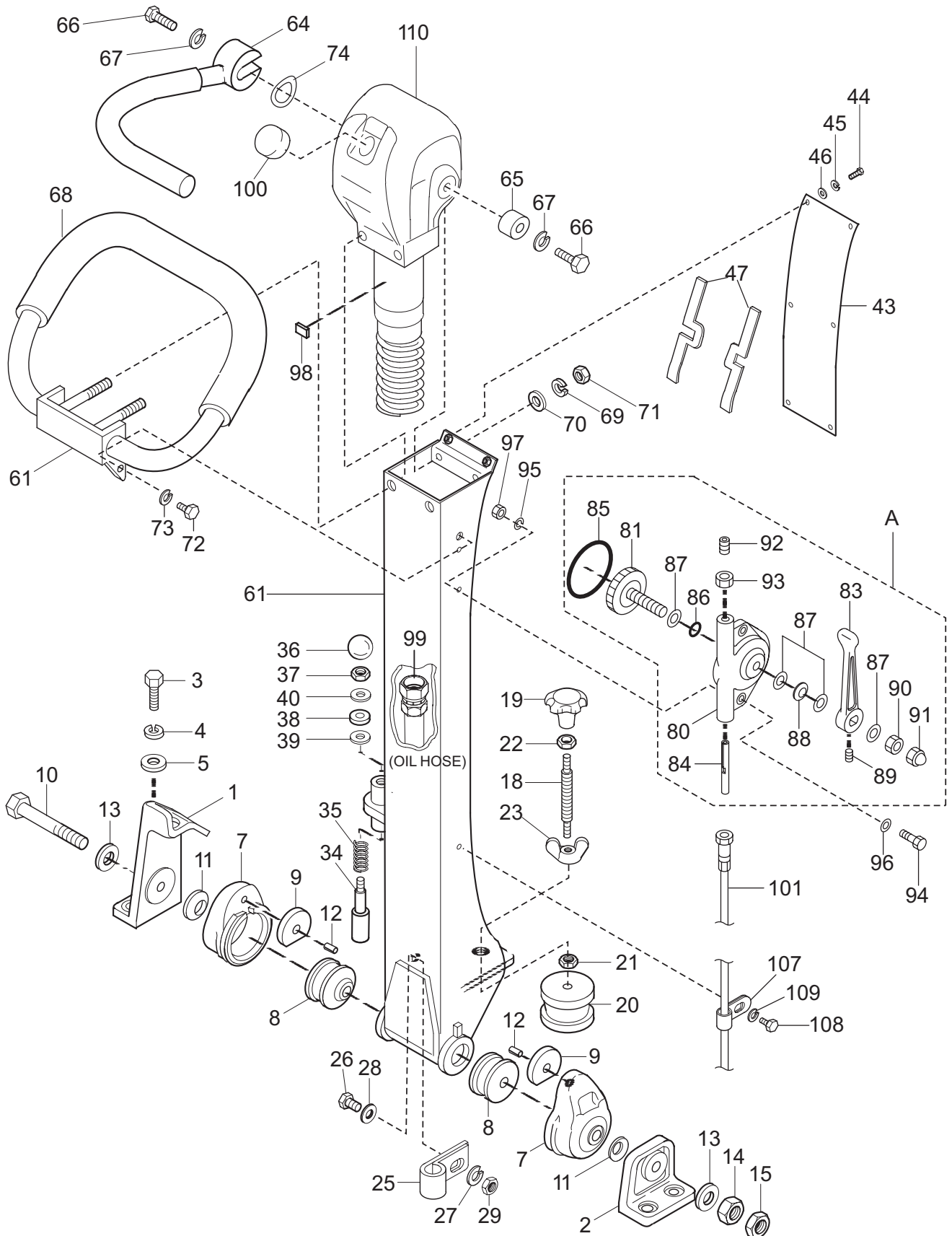

CONTROL ASSY

<u>NO.</u>	<u>PART NO.</u>	<u>PART NAME</u>	<u>QTY.</u>	<u>REMARKS</u>
66	001221030	BOLT 10X30 T	2	
67	030210250	WASHER, LOCK M10	2	
68	464216620	GRIP	1	
69	030210250	WASHER, LOCK M10	2	
70	031110160	WASHER, FLAT M10	2	
71	020310080	NUT M10	2	
72	001220825	BOLT 8X25 T	2	
73	030208200	WASHER, LOCK M8	2	
74	952010030	WAVE WASHER W-20	4	
80#	362341550	THROTTLE BODY	1	
81#	362910090	THROTTLE, GEAR CP, W/ BOLT	1	
83#	362455630	THROTTLE LEVER	1	
84#	362455620	SLIDER	1	
85#	050100450	O-RING G-45	1	
86#	050200100	O-RING P-10	1	
87#	031110160	WASHER, FLAT M10	4	
88#	032210220	CONICAL SPRING WASHER M10	1	
89#	096206006	SOCKET HEAD SCREW 6X6	1	
90#	020410060	NUT M10, H=6	1	
91#	022131008	CAP NUT M10	1	
92#	096208020	SOCKET HEAD SCREW 8X20	1	
93#	020408050	NUT M8, H=5	1	
94	001220625	BOLT 6X25 T	2	
95	030206150	WASHER, LOCK M6	2	
96	031106100	WASHER, FLAT M6	2	
97	020306050	NUT M6	2	
98	464457930	RUBBER PIECE (T2)	1	
99	954002270	OIL HOSE W/ SPRING 1/4X920	1	
100	458451630	BREATHER CAP	1	
101	956100065	THROTTLE WIRE	1	
107	20675501-01	CLAMP COMPL	3	
108	001220615	BOLT 6X15 T	1	
109	030206150	WASHER, LOCK M6	1	
110	4663-47890	HAND PUMP	1	

L70V6GF1R1AA — CYLINDER BLOCK ASSY

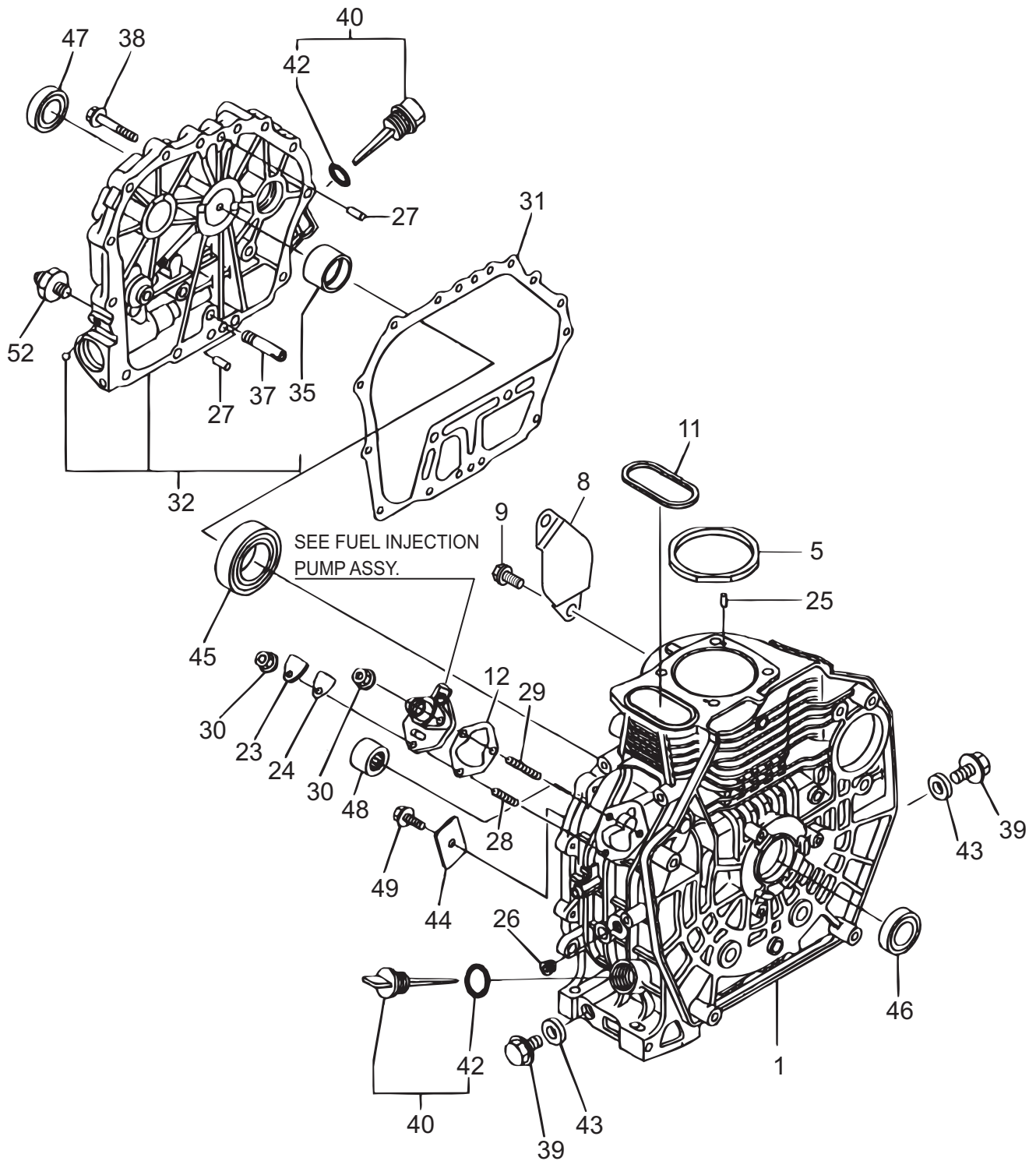

L70V6GF1R1AA — CYLINDER BLOCK ASSY

<u>NO.</u>	<u>PART NO.</u>	<u>PART NAME</u>	<u>QTY.</u>	<u>REMARKS</u>
1	11421001010	CYLINDER BLOCK ASSY.	1	
5	11439501330	CYLINDER HEAD GASKET ASSY.	1	
8	11435001800	COVER, STARTER	1	
9	26106100122	BOLT M10X20 PLATED	2	
11	11439901380	O- RING	1	
12	11429901800	SHIM SET	1	
23	11429901830	COVER (FO PUMP)	1	
24	11425001841	GASKET	1	
25	22312040080	PIN 4X8 STRAIGHT	2	
26	23875020000	PLUG PT1/4 STEEL	1	
27	11429901600	PIN, 8X12	2	
28	26226060182	STUD M 6X18 PLATED	1	
29	26226060222	STUD M 6X22 PLATED	2	
30	26366060002	NUT M6	3	
31	11439901410	CRANKCASE GASKET	1	
32	11421001460	CRANKCASE COVER D	1	INCLUDES ITEMS W/ *
35*	11435002100	MAIN BEARING US=STD.	1	
35	11435002200	MAIN BEARING US=0.25	1	
35	11435002210	MAIN BEARING US=0.50	1	
37	11429935150	L.O. INLET PIPE	1	
38	26106080352	BOLT M 8X35 PLATED	15	
39	11429901690	PLUG M16	2	
40	11469901760	OIL GAUGE CAP, W/LUB	2	INCLUDES ITEMS W/ \$
42\$	24311000180	O- RING	2	
43	22190160002	SEAL WASHER 16S	2	
44	11429902030	RETAINER	1	
45	11435002113	BALL BEARING	1	
46	16011002220	OIL SEAL	1	
47	16011002220	OIL SEAL	1	
48	24162152116	NEEDLE BEARING	1	
49	26106080122	BOLT M 8X12 PLATED	1	
52	23876010000	PLUG PT 1/8	1	

L70V6GF1R1AA — CYLINDER HEAD ASSY

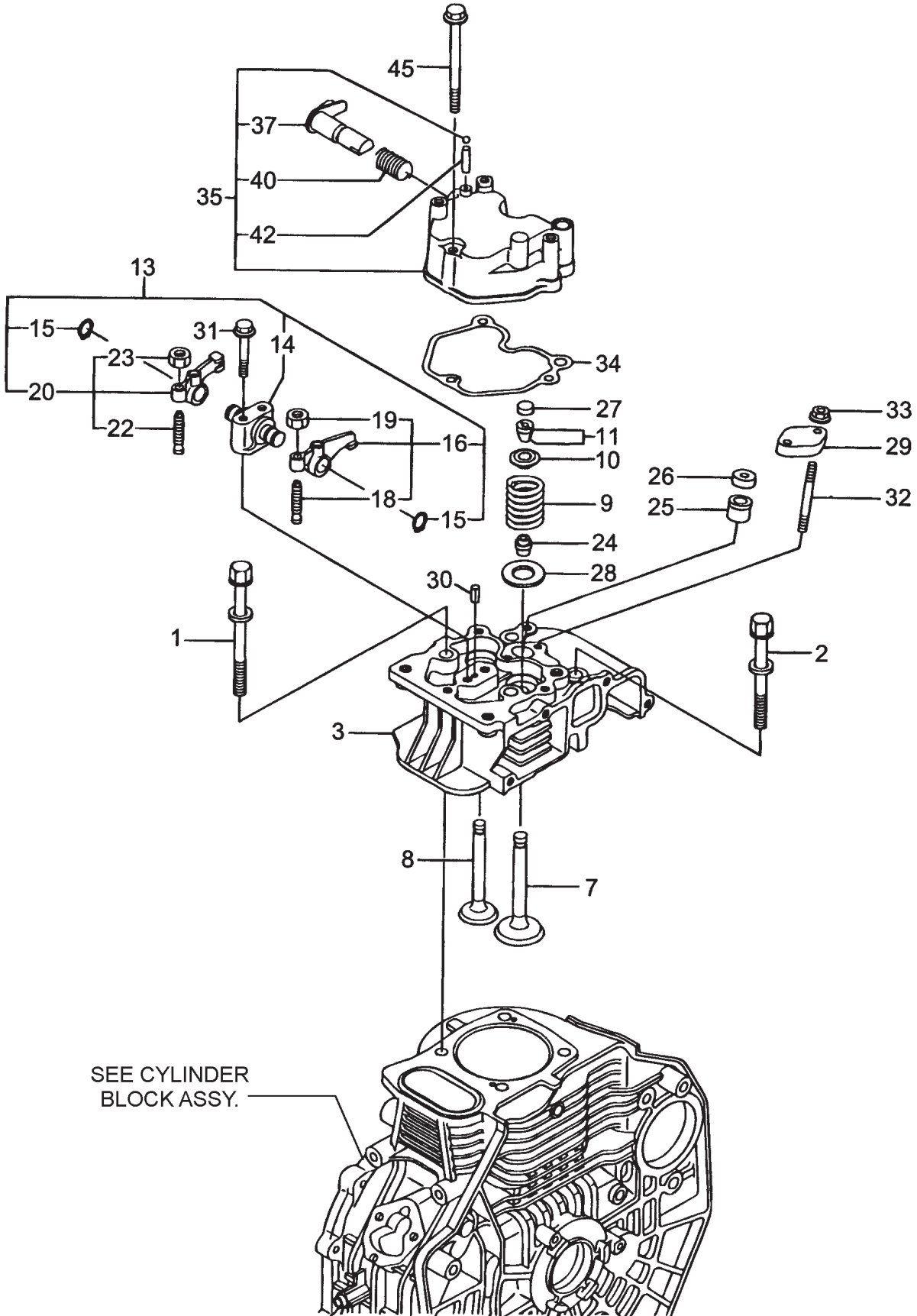

L70V6GF1R1AA — CYLINDER HEAD ASSY

<u>NO.</u>	<u>PART NO.</u>	<u>PART NAME</u>	<u>QTY.</u>	<u>REMARKS</u>
1	11421001200	CYLINDER HEAD A BOLT	2	
2	11421001210	CYLINDER HEAD B BOLT	2	
3	11421011020	CYLINDER HEAD ASSY.	1	
7	11421011100	INTAKE VALVE	1	
8	11421011110	EXHAUST VALVE	1	
9	11421011120	VALVE SPRING	2	
10	11421011180	SPRING RETAINER	2	
11	11421011930	COTTER ASSY.	2	
13	11421011250	SUPPORT ASSY. ROCKER	1	INCLUDES ITEMS W/ #
14#	11421011260	ROCKER ARM SUPPORT	1	
15#	11421011280	C TYPE RETAINING PIN	2	
16#	11421011650	INTAKE ARM ASSY.	1	INCLUDES ITEMS W/ %
18%	11429911240	ADJUSTING SCREW	1	
19%	26856060002	LOCK NUT 6	1	
20#	11421011660	EXHAUST ARM ASSY.	1	INCLUDES ITEMS W/ \$
22\$	11429911240	ADJUSTING SCREW	1	
23\$	26856060002	LOCK NUT 6	1	
24	11435011340	VALVE STEM SEAL	2	
25	11477111461	NOZZLE GASKET	1	
26	11429511470	NOZZLE SPACER	1	
27	10501011490	VALVE CAP	2	
28	11429911600	VALVE SPRING WASHER	2	
29	11421011900	NOZZLE RETAINER	1	
30	22351040008	SPRING PIN 4X8	1	
31	26106060402	BOLT M6X40 PLATED	2	
32	26226060552	STUD M 6X55	2	
33	26366060002	NUT M6	2	
34	11421011310	BONNET GASKET	1	
35	11421011950	BONNET HEAD ASSY.	1	INCLUDES ITEMS W/ *
37*	11421003590	DECOMP SHAFT ASSY.	1	
40*	11429903640	DECOMP SPRING	1	
42*	22312030160	PARALLEL PIN 3X16	1	
45	26106060552	BOLT M 6X55 PLATED	1	

L70V6GF1R1AA — AIR CLEANER ASSY

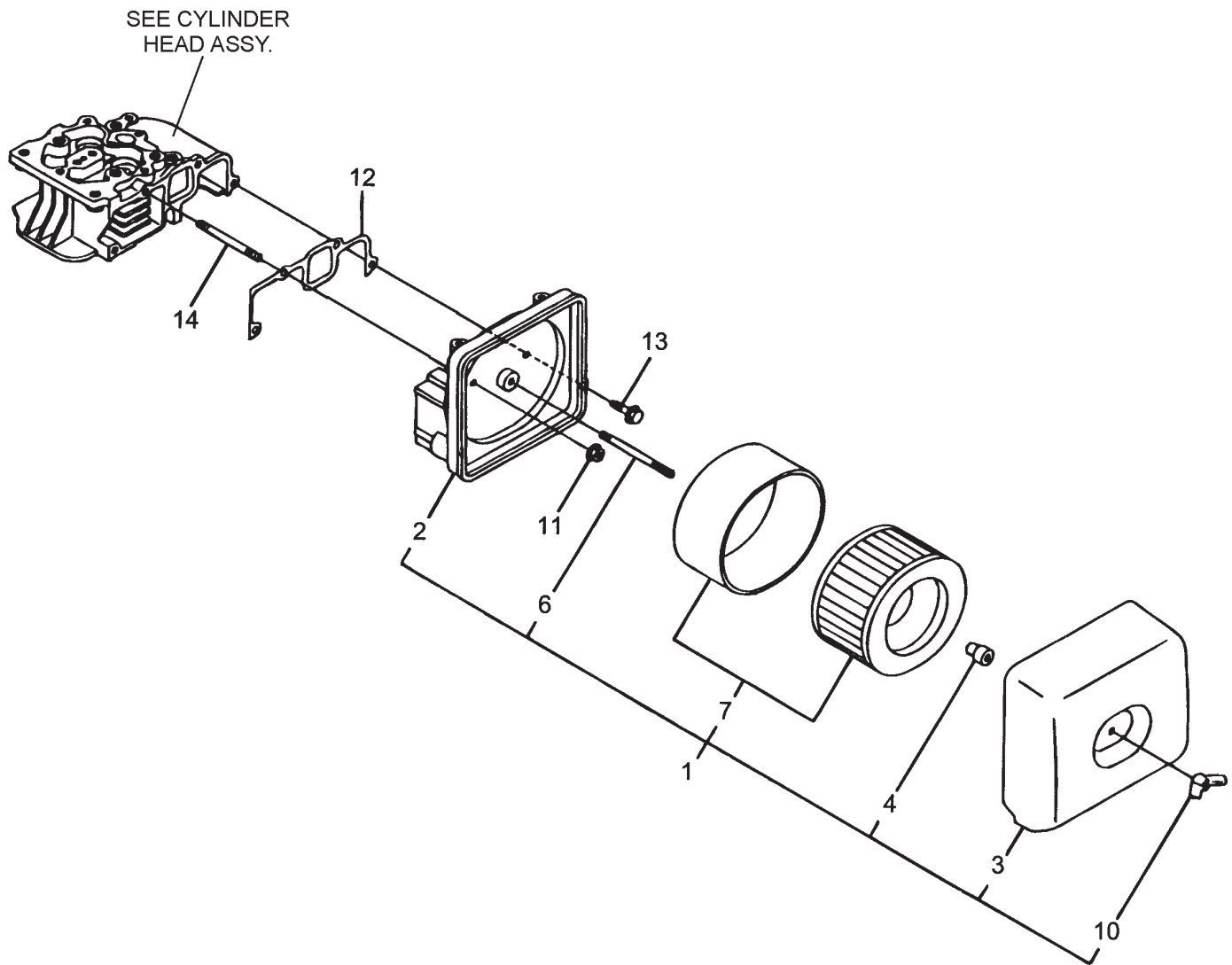

L70V6GF1R1AA — AIR CLEANER ASSY

<u>NO.</u>	<u>PART NO.</u>	<u>PART NAME</u>	<u>QTY.</u>	<u>REMARKS</u>
1	11421012510	AIR CLEANER ASSY.	1	INCLUDES ITEMS W/ *
2*	11421012020	AIR CLEANER BODY	1	
3*	11421012520	AIR CLEANER COVER	1	
4*	11421012560	WING NUT	1	
6*	11421012580	STUD BOLT	1	
7*	11421012590	ELEMENT ASSY.	1	
10*	11421012600	KNOCKING KNOB	1	
11	11429912300	U-NUT	3	
12	11421012210	AIR CLEANER GASKET	1	
13	26106060202	BOLT M 6X20 PLATED	1	
14	26226060302	STUD M 6X30	3	

L70V6GF1R1AA — MUFFLER ASSY

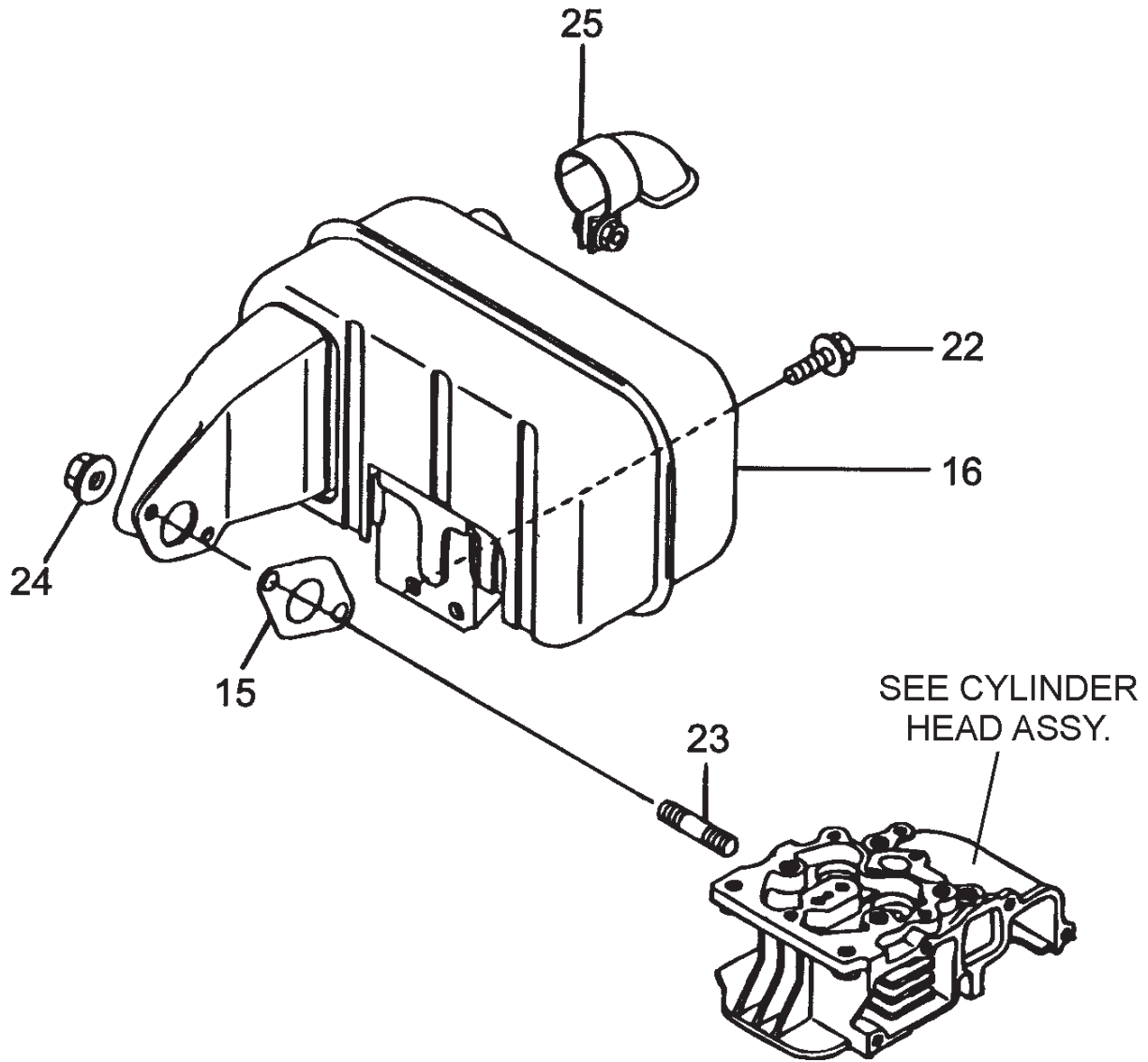

L70V6GF1R1AA — MUFFLER ASSY

<u>NO.</u>	<u>PART NO.</u>	<u>PART NAME</u>	<u>QTY.</u>	<u>REMARKS</u>
15	11429913200	MUFFLER GASKET	1	
16	11439913520	MUFFLER ASSY.	1	
22	26106060142	BOLT M 6X14 PLATED	2	
23	26216080182	STUD M 8X18 PLATED	2	
24	26366080002	NUT M8	2	
25	11429913800	EXHAUST DEFECTOR	1	

L70V6GF1R1AA — CRANKSHAFT AND CAMSHAFT ASSY

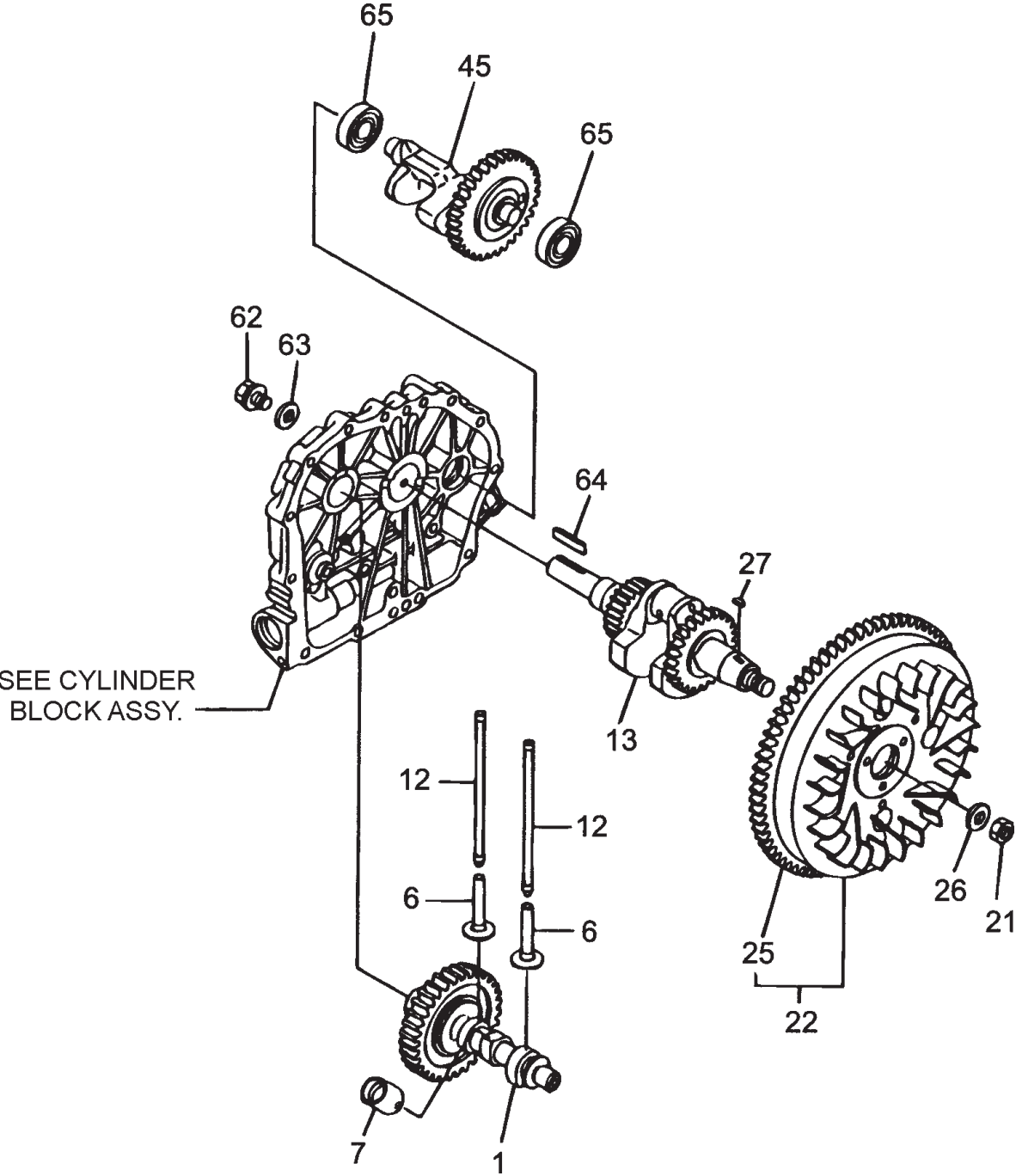

L70V6GF1R1AA — CRANKSHAFT AND CAMSHAFT ASSY

<u>NO.</u>	<u>PART NO.</u>	<u>PART NAME</u>	<u>QTY.</u>	<u>REMARKS</u>
1	71421014580	CAMSHAFT ASSY.	1	
6	11421014200	TAPPET	2	
7	11421014300	ROLLER TAPPET ASSY.	1	
12	11421014400	PUSH ROD ASSY.	2	
13	71421021740	CRANKSHAFT (D) ASSY.	1	
21	11428821220	NUT	1	
22	11439921590	FLYWHEEL (DE) ASSY.	1	INCLUDES ITEM W/ *
25*	11436221600	RING GEAR	1	
26	11429921550	FLYWHEEL WASHER	1	
27	22512040120	KEY 4X12	1	
45	71421028510	BALANCER SHAFT ASSY.	1	
62	26106080202	BOLT M 8X20 PLATED	1	
63	16031014550	WASHER	1	
64	22512070360	KEY 7X36 RR	1	
65	24101062030	BEARING	2	

L70V6GF1R1AA — PISTON ASSY

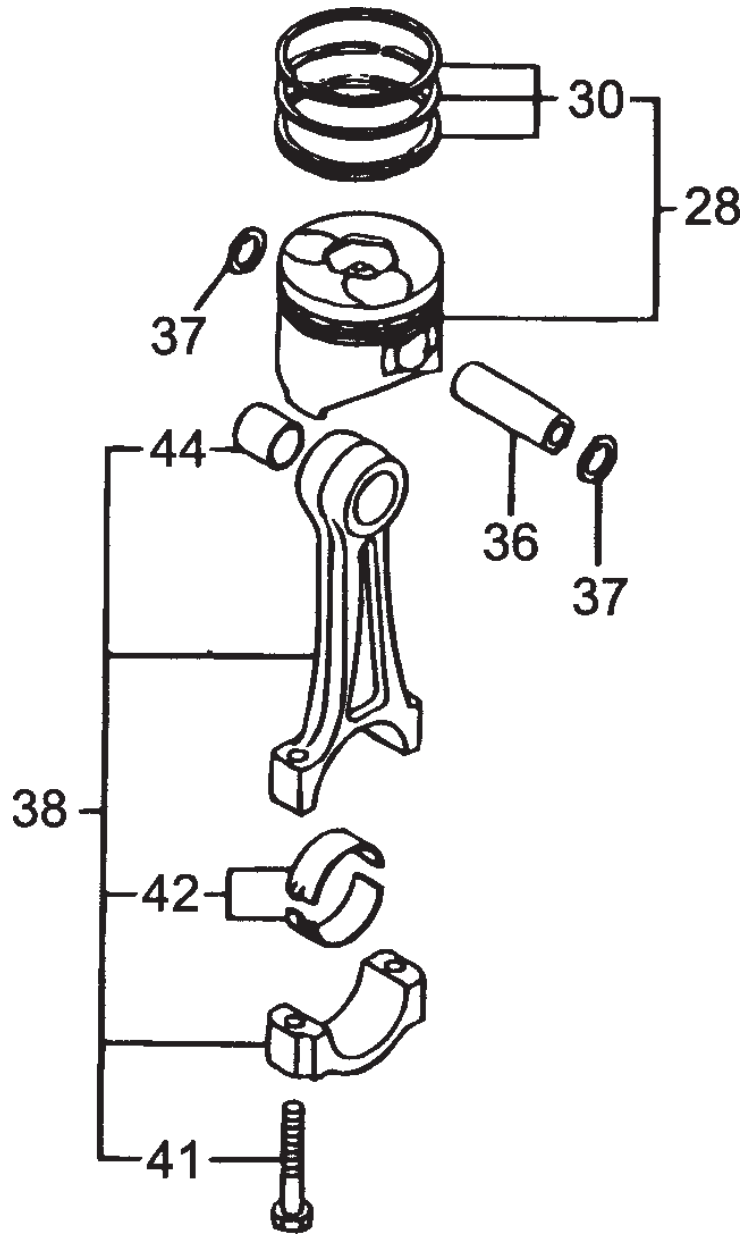

L70V6GF1R1AA — PISTON ASSY

<u>NO.</u>	<u>PART NO.</u>	<u>PART NAME</u>	<u>QTY.</u>	<u>REMARKS</u>
28	71421022720	PISTON W/ RINGS STD	1	INCLUDES ITEMS W/ #
28	71421022620	PISTON W/ RINGS OS=0.25	1	INCLUDES ITEMS W/ \$
28	71421022580	PISTON W/ RINGS OS=0.50	1	INCLUDES ITEMS W/ %
30#	71487022502	PISTON RINGS SET=STD.	1	
30\$	71487022542	PISTON RING SET 0.S.=0.25	1	
30%	71487022552	PISTON RING SET 0.2=0.50	1	
36	11439922300	PISTON PIN	1	
37	22252000210	CIRCLIP 21	2	
38	71421023700	CONNECTING ROD ASSY.	1	INCLUDES ITEMS W/ *
41*	11820023200	ROD BOLT	2	
42*	11421023600	CRANK PIN BEARING STD.	1	
42*	11421023610	CRANK BEARING PIN U.S.=0.25	1	
42*	11421023620	CRANK BEARING PIN U.S.=0.50	1	
44*	11438023100	PISTON PIN BUSH	1	

L70V6GF1R1AA — LUB. OIL PUMP AND GOVERNOR ASSY

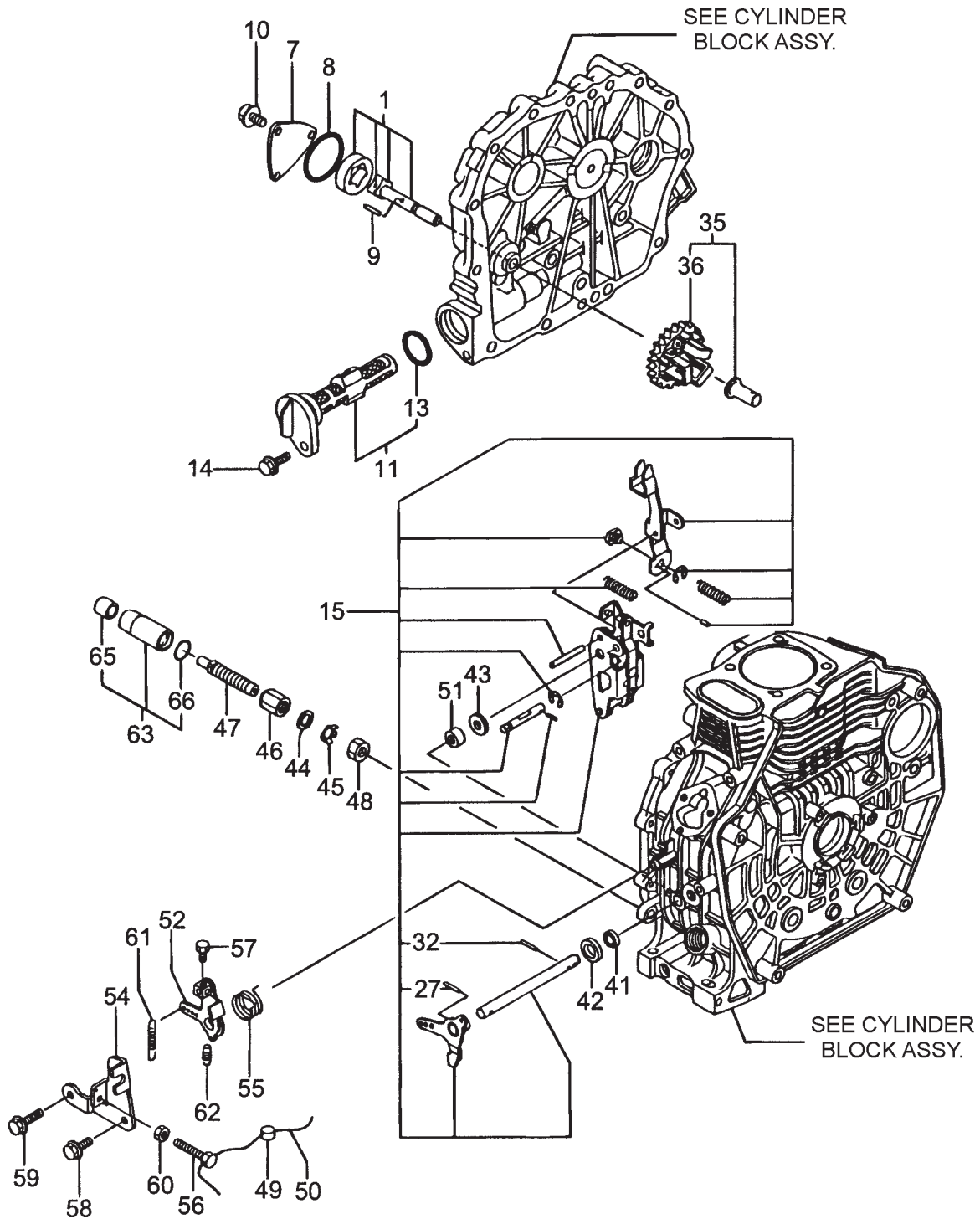

L70V6GF1R1AA — LUB. OIL PUMP AND GOVERNOR ASSY

<u>NO.</u>	<u>PART NO.</u>	<u>PART NAME</u>	<u>QTY.</u>	<u>REMARKS</u>
1	11425032010	LUB. OIL PUMP ASSY.	1	
7	11429932070	LUB. OIL PUMP COVER	1	
8	11429932570	O- RING COVER	1	
9	22312030160	PARALLEL PIN 3X16	1	
10	26106060122	BOLT M 6X12 PLATED	3	
11	11429935110	LUBE OIL FILTER COMPLETE	1	INCLUDES ITEMS W/ *
13*	24341000224	O- RING 1A S- 22.4	1	
14	26106060162	BOLT M 6X16 PLATED	1	
15	11421061500	LEVER ASSY.	1	INCLUDES ITEMS W/ #
27#	22322030200	TAPER PIN 3X20	1	
32#	22322030200	TAPER PIN 3X20	1	
35	71421061700	GOVERNOR ASSY.	1	INCLUDES ITEMS W/ +
36+	11421061290	GOVERNOR WEIGHT ASSY.	1	
41	11429961600	OIL SEAL	1	
42	11477061610	THRUST WASHER	1	
43	11429961190	GOVERNOR WASHER	1	
44	11477161810	PLAIN WASHER 14	1	
45	11477161830	PLATE	1	
46	11429561940	NUT	1	
47	11477166600	FUEL LIMITER ASSY.	1	
48	11477166690	NUT M14	1	
49	13521061090	LEAD	1	
50	22451060000	WIRE 0.6	1	
51	11477061520	NEEDLE BEARING	2	
52	11425266051	REGULATOR HANDLE	1	
54	18336066110	REGULATOR BRACKET	1	
55	11429966250	RETURN SPRING	1	
56	11429966440	ADJUSTING BOLT	1	
57	10522566990	SCREW	1	
58	26106060142	BOLT M 6X14 PLATED	1	
59	26106060202	BOLT M 6X20 PLATED	1	
60	26757060002	LOCK NUT M6 PLATED	1	
61	11421066010	REGULATOR SPRING	1	
62	11429966200	RETURN SPRING	1	
63	11477161890	PROTECTOR COMPLETE	1	INCLUDES ITEMS W/%
65%	11477161960	SPACER	1	
66%	24311000180	O- RING 1A P- 18.0	1	

L70V6GF1R1AA — COOLING AND STARTING DEVICE ASSY

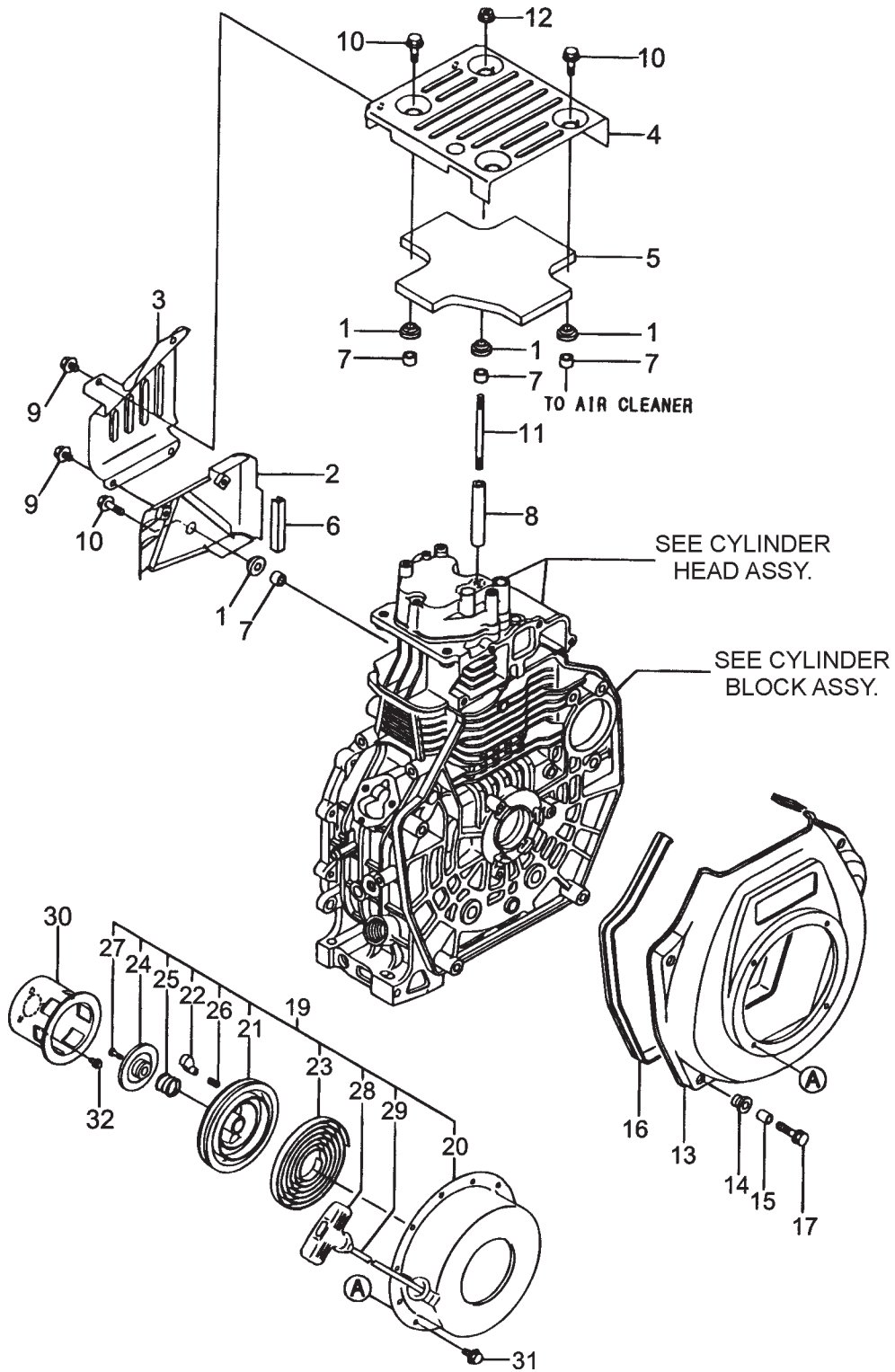

L70V6GF1R1AA — COOLING AND STARTING DEVICE ASSY

<u>NO.</u>	<u>PART NO.</u>	<u>PART NAME</u>	<u>QTY.</u>	<u>REMARKS</u>
1	11429945220	TANK GROMMET	5	
2	11421045260	SIDE COVER B (13)	1	
3	11421045270	SIDE COVER A (13)	1	
4	11421045300	TOP COVER, BLACK (13)	1	
5	11421045310	DAMPER	1	
6	11439945320	SEAL RUBBER	1	
7	11439945340	CYLINDER COLLAR COVER	5	
8	11421045350	TOP COVER SPACER	1	
9	26106060082	BOLT M 6X8 PLATED	4	
10	26106060202	BOLT M 6X20 PLATED	4	
11	26226060852	BOLT STUD 6X85	1	
12	26366060002	NUT M 6	1	
13	11421045100	FAN CASE (SILVER) (17)	1	
14	11429945300	CUSHION RUBBER	4	
15	11429945310	FAN CASE COLLAR	4	
16	11429945330	FAN CASE SEAL	1	
17	11429945350	FAN CASE BOLT	4	
19	11439976250	RECOIL STARTER (D) ASSY.....	1	INCLUDES ITEMS W/ *
20*	11439976510	STARTER CASE	1	
21*	11439976520	RECOIL REEL	1	
22*	11439976530	RATCHET	1	
23*	11439976540	SPIRAL SPRING	1	
24*	11439976550	RATCHET COVER	1	
25*	11439976560	SPRING	1	
26*	11439976570	RETURN SPRING	1	
27*	11439976580	SCREW	1	
28*	11439976620	STARTER KNOB	1	
29*	11439976630	STARTER ROPE	1	
30	11439976590	STARTER PULLEY	1	
31	26106060082	BOLT M 6 X 8 PLATED	4	
32	26106060122	BOLT M 6 X 12 PLATED	3	

L70V6GF1R1AA — FUEL INJECTION PUMP ASSY

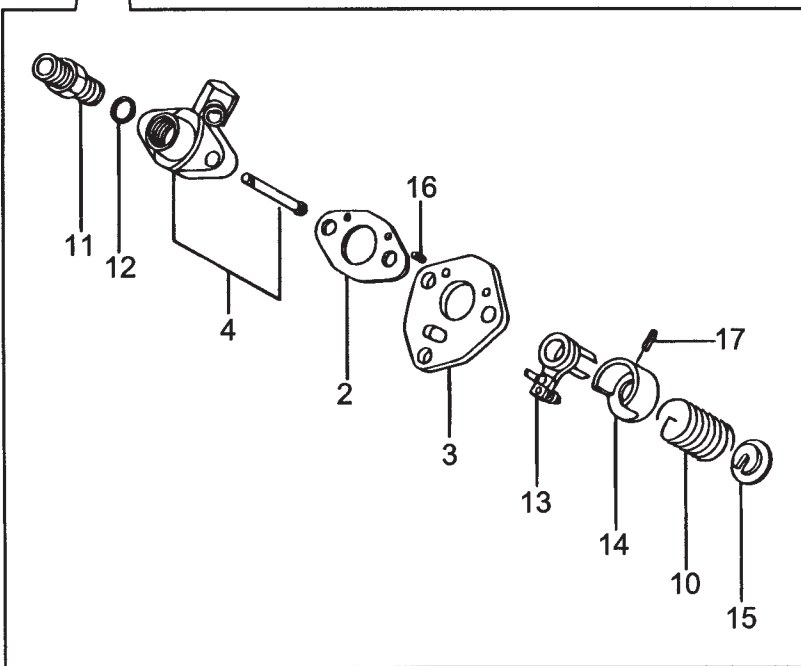
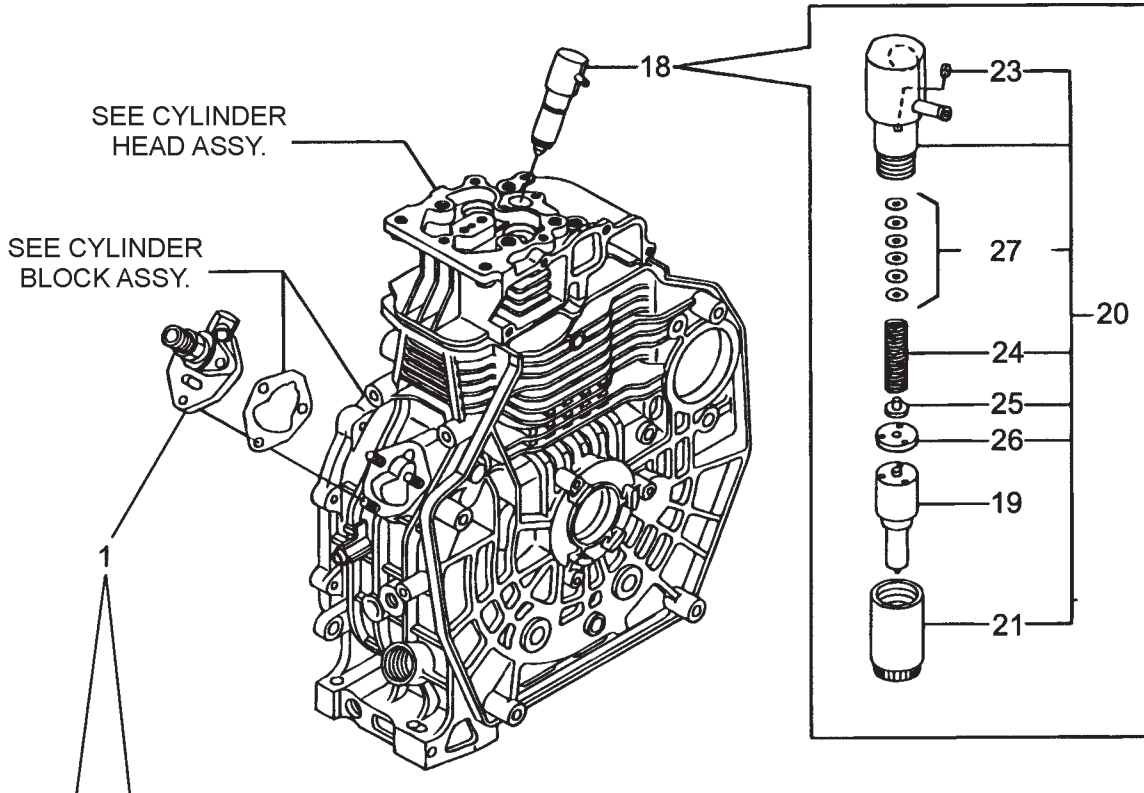

- T=1 00
- T=1 05
- T=1 10
- T=1 15
- T=1 20
- T=1 25
- T=1 30
- T=1 35
- T=1 40
- T=1 45
- T=1.50
- T=1 55
- T=1 60
- T=1 65
- T=1 70
- T=1 75
- T=1 80
- T=1 85
- T=1 90
- T=1 95
- T=2 00

SHIMS, USE AS REQUIRED FOR ITEM 27.

L70V6GF1R1AA — FUEL INJECTION PUMP ASSY

<u>NO.</u>	<u>PART NO.</u>	<u>PART NAME</u>	<u>QTY.</u>	<u>REMARKS</u>
1	71421051100	FUEL INJECTION PUMP ASSY	1	INCLUDES ITEMS W/ *
2*	10554651020	GASKET	1	
3*	11425051080	PLATE	1	
4*	11421051200	FUEL INJECTION PUMP BODY	1	
10	11425051160	SPRING	1	
11*	11421051300	DELIVERY VALVE ASSY.	1	
12*	12455051350	DELIVERY GASKET	1	
13*	11425051600	CONTROL LEVER ASSY.	1	
14*	11425051640	SPRING SEAT A	1	
15*	11425051650	SPRING SEAT B	1	
16*	22351020006	SPRING PIN 2X6	2	
17*	22351030008	SPRING PIN 3X8	1	
18	71421053100	FUEL INJECTOR	1	INCLUDES ITEMS W/ \$
19\$	11421053000	NOZZLE ASSY.	1	
20\$	11421053100	NOZZLE HOLDER ASSY.	1	INCLUDES ITEMS W/ #
21#	11421053080	NOZZLE NUT	1	
23#	11421053330	PIN	1	
24#	11421053120	NOZZLE SPRING	1	
25#	11421053130	SPRING SEAT	1	
26#	11421053140	VALVE SPACER ASSY.	1	
27#	11421053410	SHIM (T=1.00)	1	
27	11421053420	SHIM (T=1.05)	1	
27	11421053430	SHIM (T=1.10)	1	
27	11421053440	SHIM (T=1.15)	1	
27	11421053450	SHIM (T=1.20)	1	
27	11421053460	SHIM (T=1.25)	1	
27	11421053470	SHIM (T=1.30)	1	
27	11421053480	SHIM (T=1.35)	1	
27	11421053490	SHIM (T=1.40)	1	
27	11421053500	SHIM (T=1.45)	1	
27	11421053510	SHIM (T=1.50)	1	
27	11421053520	SHIM (T=1.55)	1	
27	11421053530	SHIM (T=1.60)	1	
27	11421053540	SHIM (T=1.65)	1	
27	11421053550	SHIM (T=1.70)	1	
27	11421053560	SHIM (T=1.75)	1	
27	11421053570	SHIM (T=1.80)	1	
27	11421053580	SHIM (T=1.85)	1	
27	11421053590	SHIM (T=1.90)	1	
27	11421053600	SHIM (T=1.95)	1	
27	11421053610	SHIM (T=2.00)	1	

L70V6GF1R1AA — FUEL TANK AND FUEL LINE ASSY

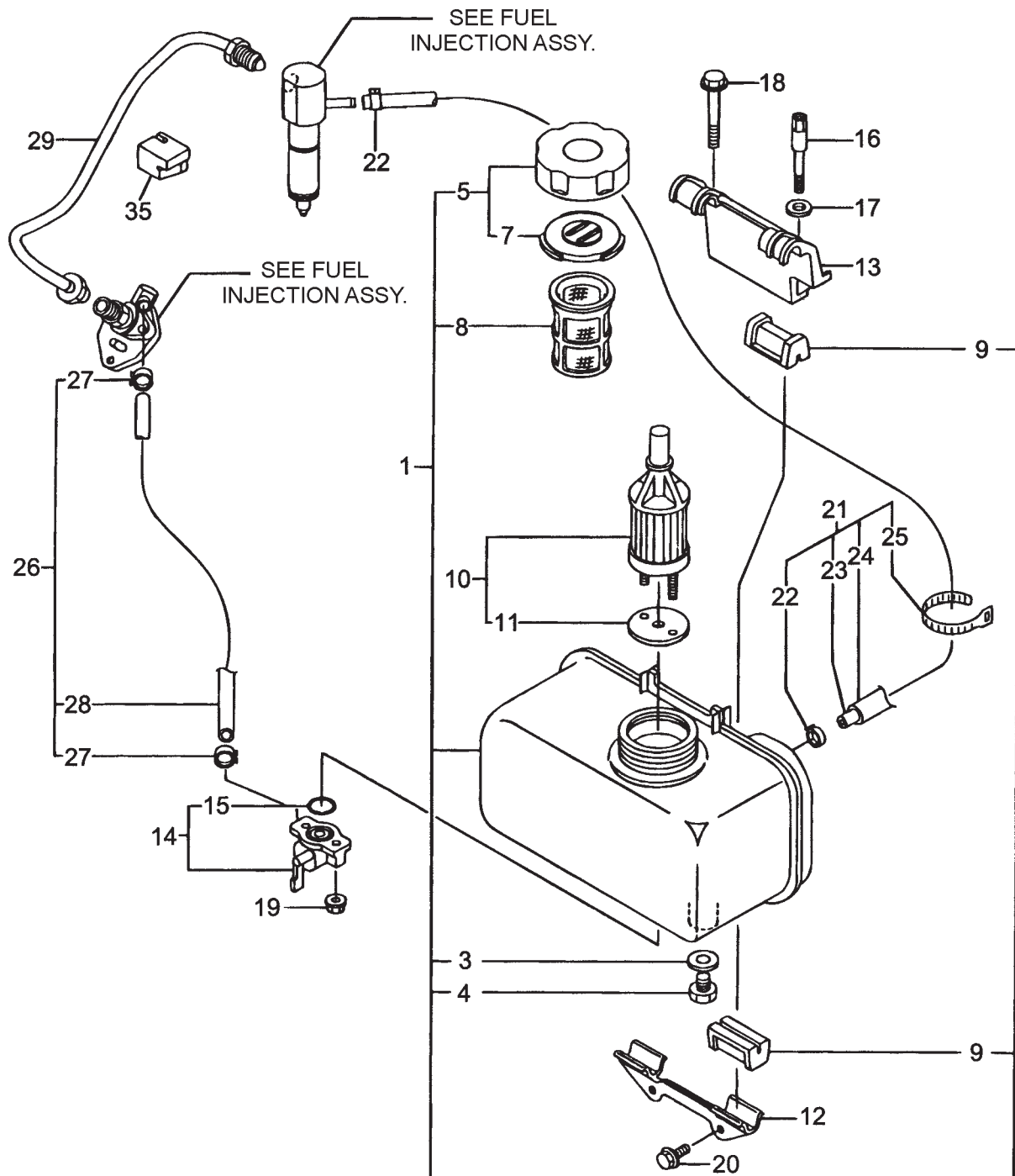

L70V6GF1R1AA — FUEL TANK AND FUEL LINE ASSY

<u>NO.</u>	<u>PART NO.</u>	<u>PART NAME</u>	<u>QTY.</u>	<u>REMARKS</u>
1	71421055700	BLACK FUEL TANK (13)	1	INCLUDES ITEMS W/ *
3*	23414080000	PACKING 8	1	
4*	10530055080	DRAIN PLUG	1	
5*	11428855041	FUEL TANK CAP ASSY.	1	INCLUDES ITEMS W/ +
7+	11428855081	CAP VALVE	1	
8*	11429955100	FUEL OIL FILTER	1	
9*	11425055201	FUEL TANK DAMPER	4	
10	11425055121	FUEL FILTER	1	INCLUDES ITEMS W/ #
11#	11425055130	GASKET	1	
12	11421055210	FUEL TANK STAY A	1	
13	11421055230	FUEL TANK STAY B	1	
14	11425055301	FUEL COCK ASSY.	1	INCLUDES ITEM W/ \$
15\$	24341000150	O- RING 1A S- 15.0	1	
16	11421055810	LIFTING BOLT	1	
17	22117080000	WASHER 8	1	
18	26106080452	BOLT M 8X 45 PLATED	1	
19	26366060002	NUT M 6	2	
20	26106060162	BOLT M 6X 16 PLATED	2	
21	11421059200	RETURN PIPE ASSY.	1	INCLUDES ITEMS W/ %
22%	12472259050	CLAMP 9	2	
23%	11465059060	FUEL RETURN PIPE	1	
24%	11465259310	PROTECT TUBE	1	
25%	12175059890	RETAINER	1	
26	11477059030	FUEL OIL PIPE ASSY.	1	INCLUDES ITEMS W/ >
27>	11427059010	HOSE CLIP	2	
28>	11426859061	FUEL OIL PIPE	1	
29	11421059800	FUEL INJECTION PIPE	1	
35	11421059850	INJECTION PIPE SUPPORT	1	

L70V6GF1R1AA — TOOLS, LABELS AND GASKETS ASSY

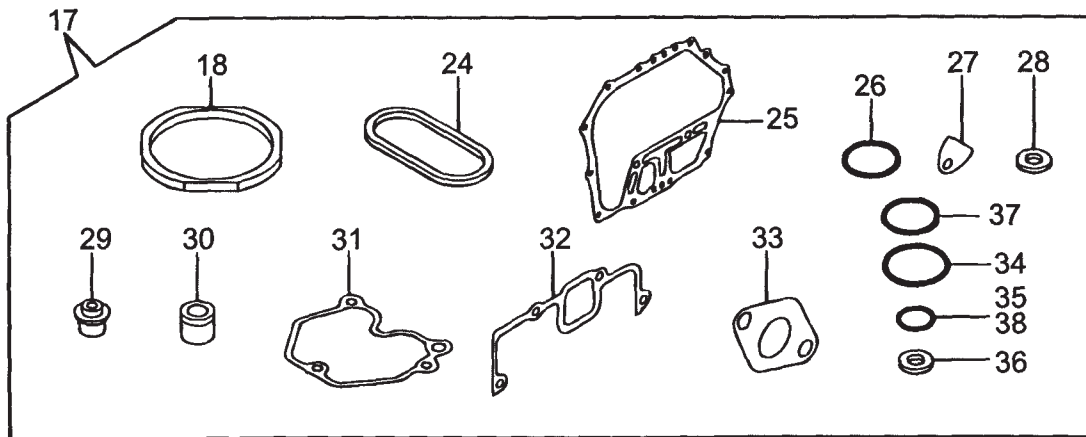
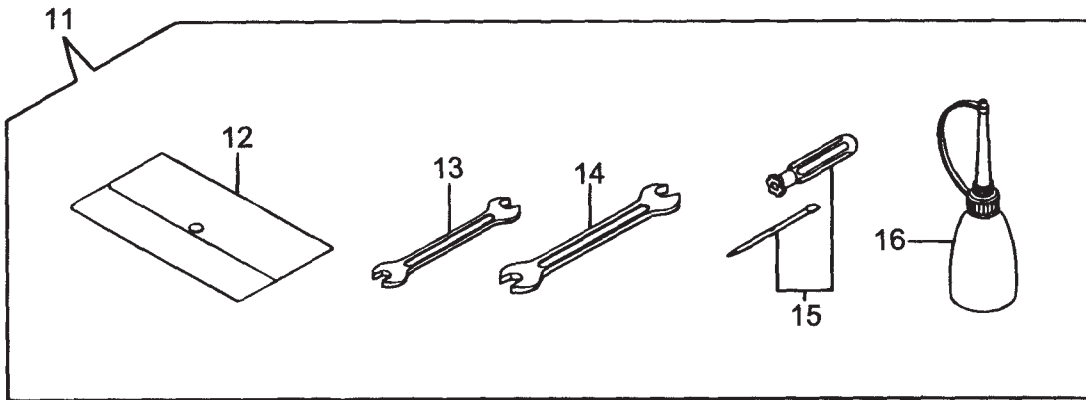
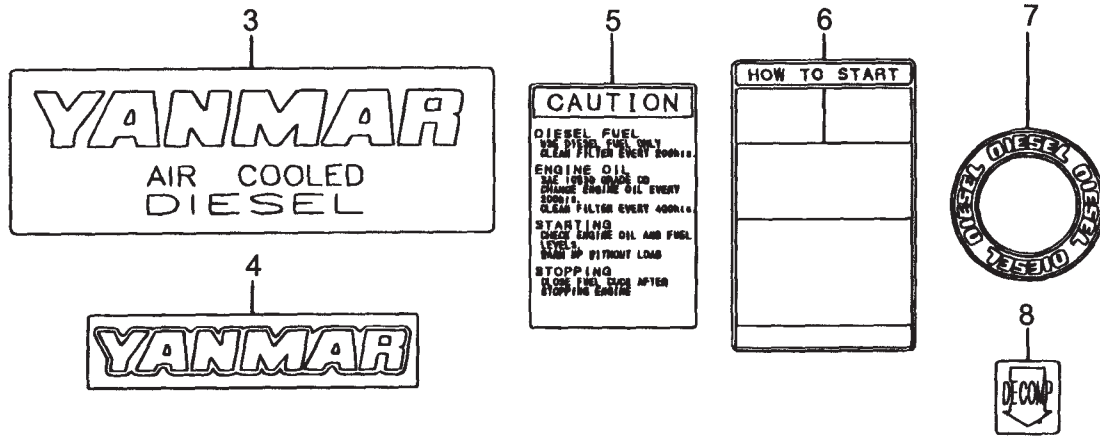

L70V6GF1R1AA — TOOLS, LABELS AND GASKETS ASSY

<u>NO.</u>	<u>PART NO.</u>	<u>PART NAME</u>	<u>QTY.</u>	<u>REMARKS</u>
3	11429907100	AIR COOLED LABEL	1	
4	11429907110	YANMAR LABEL	1	
5	11421007120	CAUTION LABEL	1	
6	11421007130	HOW TO START- E LABEL	1	
7	11429907160	DIESEL LABEL	1	
8	11421007200	DECOMPRESSION LABEL	1	
11	11429992590	TOOL ASSY.	1	INCLUDES ITEMS W/ *
12*	11429992600	TOOL BAG	1	
13*	11429992710	SPANNA	1	
14*	11429992720	SPANNA	1	
15*	11429992730	DRIVER	1	
16*	11429992740	FUEL FITTING	1	
17	71421092600	GASKET SET (NON- ASB)	1	INCLUDES ITEMS W/ #
18 #	11439501330	CYLINDER HEAD GASKET ASSY.	1	
24 #	11439901380	O- RING	2	
25 #	11439901410	CRANK CASE GASKET	1	
26 #	11429901950	O- RING	2	
27 #	11425001841	GASKET	1	
28 #	22190160002	WASHER SEAL 16S	2	
29 #	11435011340	VALVE STEM SEAL	2	
30 #	11477111461	NOZZLE GASKET	1	
31 #	11421011310	BONNET GASKET	1	
32 #	11421012210	AIR CLEANER GASKET	1	
33 #	11429913200	MUFFLER GASKET	1	
34 #	11429932570	O- RING COVER	1	
35 #	24341000100	O- RING 1A S- 10.0	1	
36 #	23414080000	PACKING 8	1	
37 #	24341000224	O- RING 1A S- 22.4	1	
38 #	24341000150	O- RING 1A S-15.0	1	

L70V6GF1R1AA — ACCESSORIES

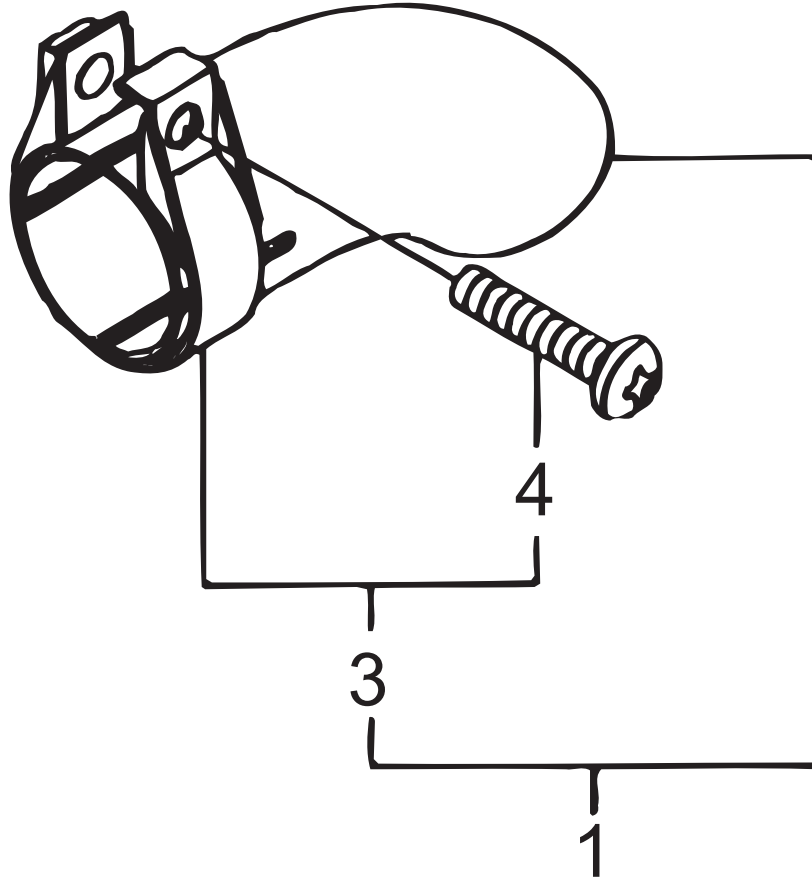

L70V6GF1R1AA — ACCESSORIES

<u>NO.</u>	<u>PART NO.</u>	<u>PART NAME</u>	<u>QTY.</u>	<u>REMARKS</u>
1	11424913600	EXHAUST PIPE ASSY.	1	INCLUDES ITEM W/ *
3*	11425213910	CLAMP	1	INCLUDES ITEM W/ #
4#	11425213960	SCREW M6X25	1	

TERMS AND CONDITIONS OF SALE — PARTS

PAYMENT TERMS

Terms of payment for parts are net 30 days.

FREIGHT POLICY

All parts orders will be shipped collect or prepaid with the charges added to the invoice. All shipments are F.O.B. point of origin. Multiquip's responsibility ceases when a signed manifest has been obtained from the carrier, and any claim for shortage or damage must be settled between the consignee and the carrier.

MINIMUM ORDER

The minimum charge for orders from Multiquip is \$15.00 net. Customers will be asked for instructions regarding handling of orders not meeting this requirement.

RETURNED GOODS POLICY

Return shipments will be accepted and credit will be allowed, subject to the following provisions:

1. A Returned Material Authorization must be approved by Multiquip prior to shipment.
2. To obtain a Return Material Authorization, a list must be provided to Multiquip Parts Sales that defines item numbers, quantities, and descriptions of the items to be returned.
 - a. The parts numbers and descriptions must match the current parts price list.
 - b. The list must be typed or computer generated.
 - c. The list must state the reason(s) for the return.
 - d. The list must reference the sales order(s) or invoice(s) under which the items were originally purchased.
 - e. The list must include the name and phone number of the person requesting the RMA.
3. A copy of the Return Material Authorization must accompany the return shipment.
4. Freight is at the sender's expense. All parts must be returned freight prepaid to Multiquip's designated receiving point.

5. Parts must be in new and resalable condition, in the original Multiquip package (if any), and with Multiquip part numbers clearly marked.
6. The following items are not returnable:
 - a. Obsolete parts. (If an item is in the price book and shows as being replaced by another item, it is obsolete.)
 - b. Any parts with a limited shelf life (such as gaskets, seals, "O" rings, and other rubber parts) that were purchased more than six months prior to the return date.
 - c. Any line item with an extended dealer net price of less than \$5.00.
 - d. Special order items.
 - e. Electrical components.
 - f. Paint, chemicals, and lubricants.
 - g. Decals and paper products.
 - h. Items purchased in kits.
7. The sender will be notified of any material received that is not acceptable.
8. Such material will be held for five working days from notification, pending instructions. If a reply is not received within five days, the material will be returned to the sender at his expense.
9. Credit on returned parts will be issued at dealer net price at time of the original purchase, less a 15% restocking charge.
10. In cases where an item is accepted, for which the original purchase document can not be determined, the price will be based on the list price that was effective twelve months prior to the RMA date.
11. Credit issued will be applied to future purchases only.

PRICING AND REBATES

Prices are subject to change without prior notice. Price changes are effective on a specific date and all orders received on or after that date will be billed at the revised price. Rebates for price declines and added charges for price increases will not be made for stock on hand at the time of any price change.

Multiquip reserves the right to quote and sell direct to Government agencies, and to Original Equipment Manufacturer accounts who use our products as integral parts of their own products.

SPECIAL EXPEDITING SERVICE

A \$35.00 surcharge will be added to the invoice for special handling including bus shipments, insured parcel post or in cases where Multiquip must personally deliver the parts to the carrier.

LIMITATIONS OF SELLER'S LIABILITY

Multiquip shall not be liable hereunder for damages in excess of the purchase price of the item with respect to which damages are claimed, and in no event shall Multiquip be liable for loss of profit or good will or for any other special, consequential or incidental damages.

LIMITATION OF WARRANTIES

No warranties, express or implied, are made in connection with the sale of parts or trade accessories nor as to any engine not manufactured by Multiquip. Such warranties made in connection with the sale of new, complete units are made exclusively by a statement of warranty packaged with such units, and Multiquip neither assumes nor authorizes any person to assume for it any other obligation or liability whatever in connection with the sale of its products. Apart from such written statement of warranty, there are no warranties, express, implied or statutory, which extend beyond the description of the products on the face hereof.

Effective: February 22, 2006

OPERATION AND PARTS MANUAL

HERE'S HOW TO GET HELP

PLEASE HAVE THE MODEL AND SERIAL
NUMBER *ON-HAND* WHEN CALLING

UNITED STATES

Multiquip Corporate Office

18910 Wilmington Ave. Tel. (800) 421-1244
Carson, CA 90746 Fax (800) 537-3927
Contact: mq@multiquip.com

Mayco Parts

800-306-2926 Fax: 800-672-7877
310-537-3700 Fax: 310-637-3284

Service Department

800-421-1244 Fax: 310-537-4259
310-537-3700

MQ Parts Department

800-427-1244 Fax: 800-672-7877
310-537-3700 Fax: 310-637-3284

Warranty Department

800-421-1244, Ext. 279 Fax: 310-537-1173
310-537-3700, Ext. 279

Technical Assistance

800-478-1244 Fax: 310-631-5032

MEXICO

MQ Cipsa

Carr. Fed. Mexico-Puebla KM 126.5 Tel: (52) 222-225-9900
Momoxpan, Cholula, Puebla 72760 Mexico Fax: (52) 222-285-0420
Contact: pmastretta@cipsa.com.mx

UNITED KINGDOM

Multiquip (UK) Limited Head Office

Hanover Mill, Fitzroy Street, Tel: 0161 339 2223
Ashton-under-Lyne, Fax: 0161 339 3226
Lancashire OL7 0TL
Contact: sales@multiquip.co.uk

CANADA

Multiquip

4110 Industriel Boul. Tel: (450) 625-2244
Laval, Quebec, Canada H7L 6V3 Fax: (450) 625-8664
Contact: jmartin@multiquip.com

© COPYRIGHT 2008, MULTIQUIP INC.

Multiquip Inc, the MQ logo and the Mikasa logo are registered trademarks of Multiquip Inc. and may not be used, reproduced, or altered without written permission. All other trademarks are the property of their respective owners and used with permission.

This manual MUST accompany the equipment at all times. This manual is considered a permanent part of the equipment and should remain with the unit if resold.

The information and specifications included in this publication were in effect at the time of approval for printing. Illustrations, descriptions, references and technical data contained in this manual are for guidance only and may not be considered as binding. Multiquip Inc. reserves the right to discontinue or change specifications, design or the information published in this publication at any time without notice and without incurring any obligations.

Your Local Dealer is:

