

Masonry Saws



Easy and Convenient





CC500M MASONRY SAW and CC400M PAVER SAW

Many Operating and Convenience Features in a Variety of Power Options



CC555M-H Gas Powered Saw
(Shown with optional stand)

- ◆ Gas or Electric Power
- ◆ Stay level guard
- ◆ Removable head
- ◆ Open throat cutting
- ◆ Legs standard on all saws
- ◆ Side Carrying Handles
- ◆ Easy, safe access to depth control lock



CC525M-E1 Electric Powered Saw
(Shown with standard legs)

- ◆ 2.5 HP electric motor is strongest dual-voltage motor on the market
- ◆ Water pump standard on all electric models
- ◆ Cooler running electric motors
- ◆ 1.5 HP electric motor draws only 13.4 amps and works on all residential circuits



CC400M Fixed Head Paver Saws

Our fixed head CC400M paver saw is the perfect low cost, low maintenance masonry saw for paver and masonry materials of all types.
For use with 14" diamond blades only

Fixed Head Paver Saws



CC425M-E1

For use with 14" diamond blades only
(CC425M-E1 shown with optional stand and wheel kit,
CC455M-H shown with optional stand)



CC455M-H



Masonry and Paver Saws



MASONRY/PAVER SAW STANDARD FEATURES



For ease of transport, we've made CC500M saw head removal simple - just pull two locking pins and lift off head. We put our cutting depth adjustment on the side of the frame so you don't have to reach around or go behind the saw.



Masonry/Paver electric saws have dual run and start capacitors for minimal amp draw at start up. Our high torque motors use a premium starter capacitor box with a sealed manual thermal overload reset. Our 2.5 HP motor is the largest dual voltage motor in its class. We outfitted our motor with a convenient front facing voltage switch and a side mounted water pump outlet.

Amp draw: 1.5 HP - 13.4 amps @ 115V
2.5 HP - 21.0 amps @ 115V

The CC500M stay-level blade guard provides the operator with safety and convenience while sawing. Our pivot mechanism resists slurry build-up, which could affect pivoting performance.



Our 5.5 HP Honda gas engine features a Cyclone Air Cleaner which protects the engine from dust and foreign material.



We enclosed the blade shaft and bearings in a slurry and dust free compartment to ensure long bearing life. The blade shaft cover plate allows easy access for greasing

bearings. Our flange block bearings make bearing replacement easy without the need for a hydraulic press or other special tools.

SAW OPTIONS

Masonry Saw Options

Description	Part No.	Cat. No.
Folding Stand	2500839	46870
Folding Stand Upgrade*	6030042	46893
Stand Wheel Kit	6030040	48547
Cord 50' 12GA 115V 20A Twist to 15A Straight	4699100	47884
Cord 100' 12GA 115V 20A Twist to 15A Straight	4699101	48548



Choose our optional Folding Stand for easier masonry saw set up and improved stability. Stand may be ordered as an upgrade instead of the standard leg set or as a separate item.



Increase the mobility of your CORE CUT® masonry saw by adding our optional Wheel Kit to a CORE CUT® folding stand.

* Must be ordered with saw. Folding stand will be shipped instead of leg kit.

CC500M Masonry Saws and CC400M Paver Saws *

Model No.	Power Source	P/N	Cat. No.	Wt.♦
CC515M-E1	1.5 HP Baldor-115/230V Electric**	5800373	46892	194 lbs.
CC525M-E1	2.5 HP Baldor-115/230V Electric**	5800375	46901	196
CC530M-E1	3.0 HP Baldor-1PH-230-50HZ Electric	5800424	47294	205
CC555M-H	5.5HP Honda	5800376	47036	172
CC415M-E1	1.5 HP Baldor-115/230V Electric**	5800377	48545	178
CC425M-E1	2.5 HP Baldor-115/230V Electric**	5800378	48546	180
CC455M-H	5.5 HP Honda	5800379	47624	210

* Water pump is standard on all models.

♦ Add 25 lbs. for crated weight.

** All electric motors are single phase.

CC500M/CC400M Dimensions

	Dimension	CC500M*	CC400M**
A	Saw Length	34"	36-3/4"
B	Saw Width	24-3/4"	24-3/4"
C	Saw Height	32-7/8"	28"
D	Stand Height	27"	27"
E	Total Height	58-3/8"	53-1/2"
F	Arbor Height Over Cart	15-3/8"	6-3/4"
G	Cart Travel	20-3/4"	20-3/4"

* Dimensions for CC500M are with electric motor with cutting head raised to maximum height.

** Dimensions for CC400M are with gasoline engine.

CC400M/500M Specifications

Maximum Depth of Cut:	4-3/4" (CC400) and 5" (CC500)
Blade Shaft Diameter:	7/8"
Arbor Diameter:	1"
Blade Shaft Bearings:	Flange block ball bearings
Blade Shaft Drive:	2 belt
Blade Mounting:	Right (CC500 electric), left (CC500 gas, all CC400)
Blade Raise and Lower:	Counterbalanced, spring tensioned head pivots on (2) 7/8" flange block bearings (CC500) Fixed head (CC400)
Blade Coolant:	Dual spray tubes, pump fed (electric motors) garden hose connection gas units
Air Filter:	3 stage Cyclone (gasoline models only)
Fuel Capacity:	1 Gallon
High Temperature Shut-Off:	Standard (electric models only)
Starter:	Recoil on gasoline models, capacitor on electric models

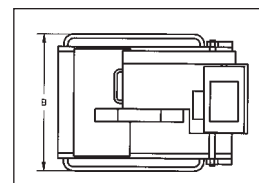
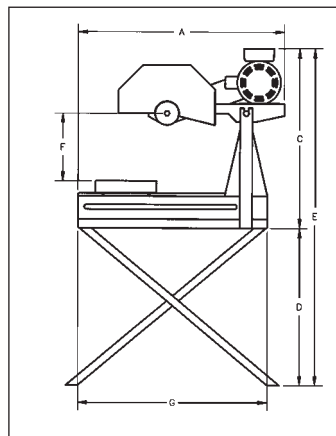



NEW MASONRY and PAVER SAWS

CC300M Masonry Saw

Value Priced, Durable and Easy To Use

Our most economically-priced masonry saw

Longer motor life thanks to a superior air filter.

Includes 2 spare air filters



Powerful 2 HP motor

Durable design

14" Blade Capacity

Tool-free air filter replacement



Available with optional wet kit that converts the CC300M into a wet cutting saw. (P/N 6043058)

CC300M Specifications

Power Supply	115V/60Hz
Power	2 HP
Amp Draw	15A
RPM	3600
Blade Capacity	14"
Max. Depth of Cut	5"
Max. Length of Cut	16"
Material Size	8" x 8" x 16"
Weight	80 lbs.
Saw Height	24"
Saw Length	28"
Saw Width	23"

CC300M Masonry Saw

Description	Part No.	Cat. No.
CC300M	5800730	84807
Optional Wet Kit	6043058	90644

CC407DF Dust Free Paver Saw



- ◆ Dust free dry cutting saw - vacuum hose attaches to the saw.
- ◆ Choice of powerful 6.5 HP Honda or 7.0 HP Robin motors
- ◆ Cuts up to 16" x 16" patio paver
- ◆ 14" maximum blade capacity
- ◆ Quickly turns into a true wet saw
- ◆ Easy cleaning of round dust tube

Core Cut CC407DF Dust Free Masonry Saw

Part Number	Catalog Number	Description
5800720	86719	CC407DF-H Dust Free Paver Saw with 6.5 HP Honda
5800721	86718	CC407DF-R Dust Free Paver Saw with 7.0 HP Robin

CC407DF Specifications

Saw Dimensions	
Length	46"
Width	24"
Height	29"
Weight	225 lbs



Masonry and Paver Saws





CC800M SERIES BLOCK SAWS

**Delivers Productivity, Power and Safety
while Handling Up To a 24" Blade!**

20" or 24" Blade Capacity
(8" or 10" Cutting Depths)

24" Blade Cuts a
10" Concrete Block
in a Single Pass

Foot Pedal Controlled
Operating Head Leaves
Operators Hands Free to
Guide Material
Being Cut

Replaceable Conveyor Rails

Durable 3/16" Steel Frame

Stay Level
Blade Guard and
Enclosed Blade Shaft

Easy Rolling 16" x 25"
Aluminum Cutting Cart
with Vulcanized Rubber
Non-slip Top

Water Pump Standard
on All Models

Forklift Openings
for Easy Transport

*CC800M Gas Block Saw with
13 HP Honda Motor and 24" Blade Guard*

- ◆ 20" or 24" blade capacity (8" and 10" cutting depths)
- ◆ 24" blade cuts a 10" concrete block in a single pass
- ◆ Choose from 9 HP and 13 HP gasoline powered models or 5 HP and 7.5 HP electric models
- ◆ Stay level steel blade guard assures blade guard is parallel to cutting cart at all times
- ◆ Easy rolling 16" x 25" aluminum cutting cart with vulcanized rubber to support large materials
- ◆ 2 V-belts for efficient delivery of power
- ◆ Durable 3/16" steel frame for minimum vibration
- ◆ Hand wheel for quick and easy blade cutting depth adjustment
- ◆ Foot pedal controlled cutting head leaves operators hands free
- ◆ Enclosed blade shaft to protect greasable ball bearings
- ◆ Replaceable conveyor cart support rails
- ◆ Open back design for rip cutting of longer materials
- ◆ Large capacity, deep tapered water pan for water flow
- ◆ Greasable ball bearings pivot points for cutting head



CC800M BLOCK SAW SPECIFICATIONS

CC800M 5HP Single Phase
Electric Block Saw with
20" Blade Guard



CC800M Block Saws

CC800M Specifications	
Blade Capacity	20" and 24"
Maximum Depth of Cut	8" (20" Blade Capacity Models) 10" (24" Blade Capacity Models)
Arbor Diameter	1"
Water Pump	Standard on all models
Blade Shaft Drive	Matched set of 2 premium gripnotch V-belts
Blade Raise and Lower	Counterbalanced, spring tensioned head pivots on (2) 1" flange block bearings
Blade Coolant	Dual spray tubes, pump fed (electric motors) pump from pan (gas units)
Air Filter	3 stage Cyclone (gasoline models only)
Fuel Capacity	1 Gallon
High Temperature Shut-Off	Standard (electric models only)
Starter	Recoil on gasoline models, capacitor on electric models

20" and 24" Blade Capacity Electric Block Saw Models

Model No.	Engine Type	Part No.	Cat. No.	Blade Capacity	RPM at Blade Shaft	Uncrated Wt. *
CC850-E1-20	5 HP Baldor Electric 1 PH 230 Volts 60 HZ, 23 amps	5800540	46820	20"	2100	460 lbs.
CC850-E3-20	5 HP Baldor Electric 3 PH 230 / 460 Volts, 60 Hz 13.4 / 6.7 Amps	5800541	46860	20"	2100	480
CC875-E1-20	7.5 HP Baldor Electric 1 PH 230 Volts, 60 Hz, 32 Amps	5800542	47664	20"	2100	490
CC875-E3-20	7.5 HP Baldor Electric 3 PH 230 / 460 Volts, 60 Hz 20.4 / 10.2 Amps	5800544	46582	20"	2100	480
CC875-E3-20-575V	7.5 HP Baldor Electric 3 PH 575 Volts, 60 Hz, 8 Amps	5800549	48549	20"	2100	480
CC875-E1-24	7.5 HP Baldor Electric 1 PH 230 Volts, 60 Hz, 32 Amps	5800543	47630	24"	2100	480
CC875-E3-24	7.5 HP Baldor Electric 3 PH 230 / 460 Volts, 60 Hz, 20.4 / 10.2 Amps	5800545	47640	24"	2100	470
CC875-E3-24-575V	7.5 HP Baldor Electric 3 PH 575 Volts, 60 Hz, 8 Amps	5800550	48550	24"	2100	490

* Add 70 pounds for crated weight.

20" and 24" Blade Capacity Gas Powered Block Saw Models

Model No.	Engine Type	Part No.	Cat. No.	Blade Capacity	RPM at Blade Shaft	Uncrated Wt. *
CC809H-20	9 HP Honda Gas Engine 6.4 qt. fuel capacity	5800546	47024	20"	2100	510 lbs.
CC813H-20	13 HP Honda Gas Engine 6.9 qt. fuel capacity	5800547	47047	20"	2100	530
CC813H-24	13 HP Honda Gas Engine 6.9 qt. fuel capacity	5800547	47046	24"	2100	530

All gas powered have an oil capacity of 1.16 qts. and have a cyclone air cleaner.

*Add 70 pounds for crated weight.

CC813H-24 Block Saw
with 13HP Honda motor



20" and 24" Core Cut® masonry blades maximize the productivity of your CC800 Block Saw (available in standard, heavy duty and premium grades)

CC800M Dimensions

Dimension	
A Saw Length	54"
B Saw Width	24"
C Saw Height	72"
D Arbor Height Over Cart	16"
E Cart Travel	20-3/4"

Weight: approximately 500 lbs.
(add 70 lbs. for crated weight)

