

Pump Selection Handbook

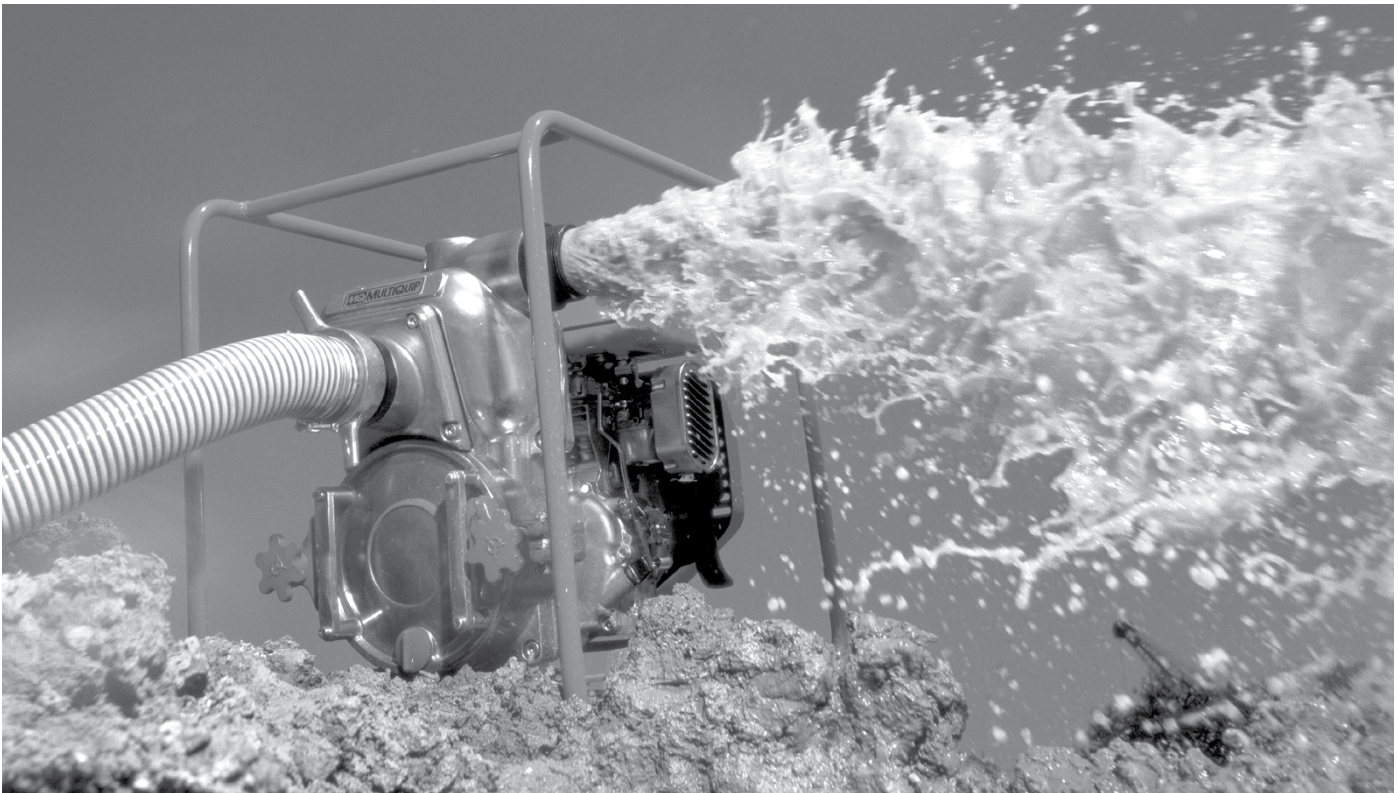



Let's Talk About Pumps

How many pumps do you own? It's actually a very interesting question. If you asked a contractor or rental store operator they might respond with a number anywhere between 1 and 50. On the other hand a layperson might reply that he has no need for pumps in his home or workplace. So, getting back to our original question, *how many pumps do you own?*

Even if you think you don't own any, the chances are very good that you own a few pumps and simply forgot to consider them. Pumps are among the most widely manufactured items in the world and their many designs permit their use in a variety of applications. They are used in everything from washing machines, refrigerators, cars and trucks to construction sites, wastewater treatment facilities and food-processing plants.

Pumps make possible many everyday tasks that we often take for granted. Indeed without pumps our world would be a much different place than we know it today.

Pumps & The Contractor

As noted previously, there are many types of pumps available in today's market. Yet there is not one pump ideally suited for every application. Since Multiquip primarily targets the construction industry our pumps are engineered to meet the requirements of the professional contractor.

Construction is a competitive business with deadlines and budgets that contractors have to meet in order to be successful. A heavy storm can set a job back several days or even weeks. Prolonged downtime can cost contractors substantial amounts of money since bonuses are often paid for finishing jobs under budget and ahead of schedule. Ask a contractor this question, "What do you expect out of a water pump?" and the answers will

likely be along these lines:

- **Performance** — the ability to quickly move a high volume of water
- **Low Downtime** — the ability to pass debris without clogging
- **Durability** — the ability to withstand harsh work environments
- **Value** — all of the above features at an economical price

Centrifugal. High-pressure. Trash. Submersible. Diaphragm. Self-priming. Zero-prime. With so many types of pumps available to contractors, how can you be sure what to recommend for a specific application? Once you become familiar with the characteristics of the most common rental pumps it's actually easier than you might think.

Common Water Pump Designs

While many pumps can be found on job sites there are two very general types of water pumps in the construction industry. Different in design and application they each basically serve the same purpose, which is to move water from point A to point B.

The first type of pump is the **centrifugal** design. This type uses a rotating impeller to draw water into the pump and pressurize the discharge flow. Common rental pumps include standard, trash and submersible models.

The second type of pump is the **positive displacement** design, the most common of which is the diaphragm type. These pumps deliver a fixed amount of flow per cycle through the mechanical contraction and expansion of a flexible diaphragm.

These pumps will be covered in greater detail later after reviewing some basic pump theory.

The Basics Of Pump Theory

It is common for customers to say they need a pump to suck water out of a hole or trench. However, centrifugal and diaphragm pumps do not actually suck water so much as they raise or lift it with help from mother nature.

Water, like electricity, will always flow along the path of least resistance. In order to lift water the pump must provide a path (area of low pressure) to which water will naturally seek to flow.

It is critical then to recognize the role atmospheric pressure plays in creating suction lift. At sea level the atmosphere exerts a force of 14.7 lb/in² (PSI) on the earth's surface. The weight of the atmosphere on a body of water will prevent lift from occurring unless vacuum is created.

Figure 1 shows three hollow tubes, each with a surface area of 1-square inch, rising from sea level up into the atmosphere. In tube (A) atmospheric pressure is the same inside the tube as it is outside: 14.7 PSI. Since the weight of the atmosphere is being exerted equally across the surface, no change occurs in the water level inside the tube.

In tube (B) a perfect vacuum is created making atmospheric pressure greater on the water outside the tube. The resulting differential causes water, flowing naturally to the area of lowest pressure to begin filling the tube until it reaches a height of 33.9-feet.

Why is 33.9-feet the highest water can be lifted in this example? Because at this point the weight of the water inside the tube exerts a pressure equal to the weight of the atmosphere pushing down on the ocean's surface. This height represents the maximum

theoretical suction lift and can be verified using the following calculation.

Divide atmospheric pressure at sea level by .0361 lb/in³ (the weight of one cubic inch of water) to obtain the theoretical suction lift.

$$14.7 \text{ (lb/in}^2\text{)} \div .0361 \text{ (lb/in}^3\text{)} = 407.28 \text{ (in)}$$

$$407.28 \text{ (in)} \div (12 \text{ in/foot)} = 33.9 \text{ (ft)}$$

Remember that 33.9-feet is the maximum theoretical height water can be lifted under perfect conditions at sea level. It does not take into consideration altitude, friction loss, temperature, suspended particles or the inability to create a perfect vacuum. All these variables affect pump performance and reduce theoretical suction lift. The practical suction lift, attainable for cold water (60°F) at sea level by creating a partial vacuum, is the 25-foot reflected in tube (C).

Centrifugal Designs

The overwhelming majority of contractor pumps use centrifugal force to move water. Centrifugal force is defined as the action that causes something, in this case water, to move away from its center of rotation.

All centrifugal pumps use an impeller and volute to create the partial vacuum and discharge pressure necessary to move water through the casing. The impeller and volute form the heart of a pump and help determine its flow, pressure and solid handling capability.

An impeller is a rotating disk with a set of vanes coupled to the engine/motor shaft that produces centrifugal force within the pump casing. A volute is the stationary housing in which the impeller rotates that collects, discharges and re-circulates water entering the pump. A diffuser is used on high-pressure pumps and is similar to a volute but more compact in design. Many types of material can be used in their manufacture but cast iron is most commonly used for construction applications.

In order for a centrifugal, or self-priming, pump to attain its initial prime the casing must first be manually primed or filled with water. Afterwards, unless it is run dry or drained, a sufficient amount of water should remain in the pump to ensure quick priming the next time it is needed.

As the impeller churns the water (Figure 2), it purges air from the casing creating an area of low pressure, or partial vacuum, at the

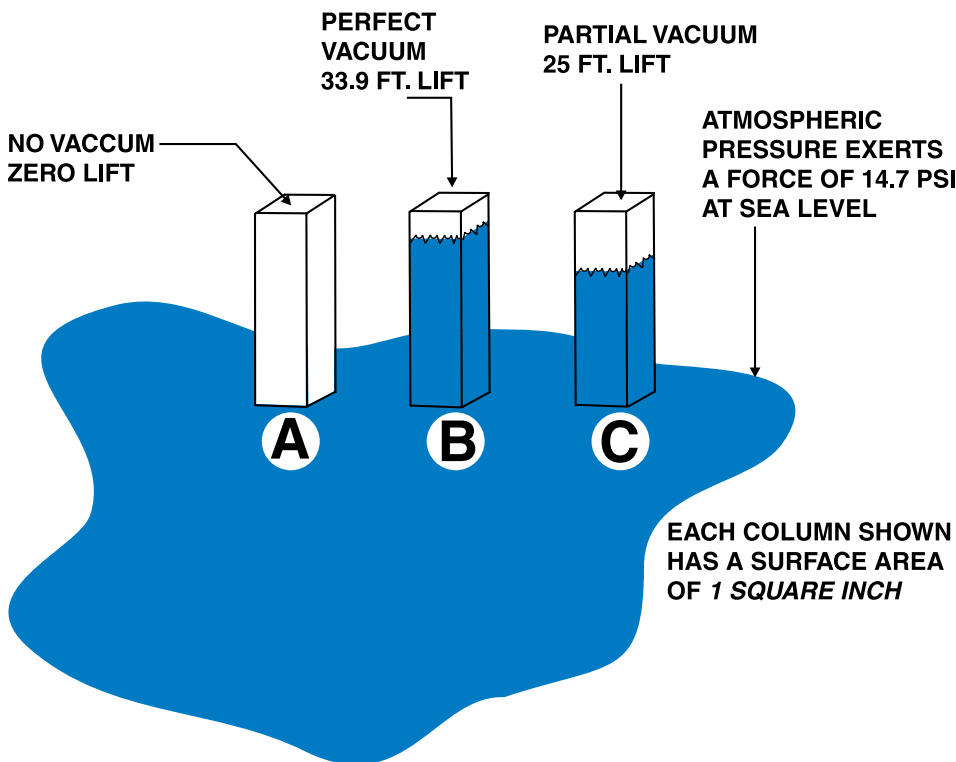

Figure 1

eye (center) of the impeller. The weight of the atmosphere on the external body of water pushes water rapidly through the hose and pump casing toward the eye of the impeller.

Centrifugal force created by the rotating impeller pushes water away from the eye, where pressure is lowest, to the vane tips where pressure is the highest. The velocity of the rotating vanes pressurizes the water forced through the volute and discharged from the pump.

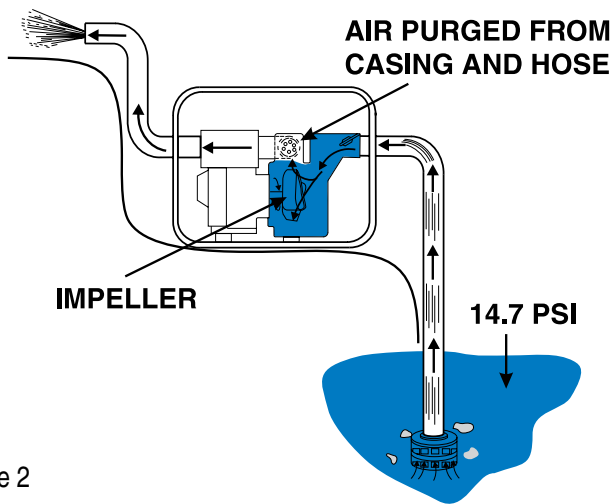

Figure 2

If The Pump Is Self-Priming Why Do I Need To Add Water?

Most centrifugal pumps require the pump casing to be filled with water (manually primed) before starting. Self-priming is a term used to generally describe many centrifugal pumps. This simply means the needs water added to the casing in order to create a partial vacuum to remove the air from the suction hose and pump casing allowing water to flow freely into the pump.

There are many high-end pumps on the market that do not need to be manually primed before operation. These pumps are generally referred to as Prime-assist pumps. They use a vacuum pump or an air compressor to remove the air out of the suction hose and pump body in order to prime the pump. This enables the pump to start dry and re-prime itself without manually adding water. In addition, these pumps can be used when lots of air has to be moved such as with well point dewatering systems.

Water passing through the pump brings with it solids and other abrasive material that will gradually wear down the impeller or volute. This wear can increase the distance between the impeller and the volute resulting in decreased flows, heads and longer priming times. Periodic inspection and maintenance is necessary to keep pumps running like new.

Another key component of the pump is its *mechanical seal*. This spring-loaded component consists of two faces, one stationary and another rotating, and is located on the engine shaft between the impeller and rear casing (Figure 3). It is designed to prevent water from seeping into and damaging the engine. Pumps designed for work in harsh environments will require a seal that is more abrasion resistant.

Typically seals are cooled by water as it passes through the pump. If the pump is dry or has insufficient water for priming it could damage the mechanical seal. Oil-lubricated and occasionally grease-lubricated seals are available on some pumps that provide positive lubrication in the event the pump is run without water. The seal is a common wear part that should also be periodically inspected.

Regardless of whether the application calls for a standard, high-pressure, or trash, every centrifugal pump lifts and discharges water in the same way. The following section will point out design differences between these pumps.

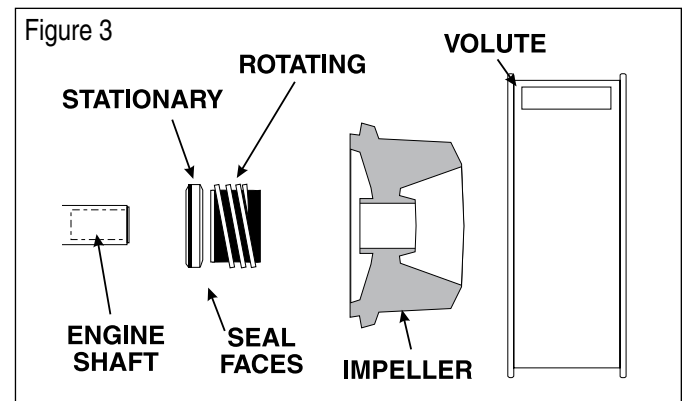

Standard Centrifugal Pumps

Standard centrifugal pumps provide an economical choice for general purpose dewatering. A number of different sizes are available but the most common model offerings are in the 2 to 4-inch range with flows from 142 to 500 gallons per minute (GPM) and heads in the range of 90 to 115 feet.

These pumps should only be used in clear water applications (agricultural, industrial, residential) as they have a limited solid handling capability of only 10% by volume. The impellers typically use a three-vane design (Figure 4A), and the volute (Figure 4D) is compact, preventing the passage of large solids. The rule of thumb is the pump will only pass spherical solids $\frac{1}{4}$ the diameter of the suction inlet.

One advantage these pumps have over comparably sized trash models is their low initial cost. There are several reasons for this difference. Lower horsepower engines are utilized that are smaller in size and more fuel-efficient. The mechanical seals, since they are not subjected to harsh working conditions, can be made of less costly material. Additionally, the casings are smaller and have fewer machined parts that when combined with the smaller engines make the pumps much lighter in weight.

High-pressure Centrifugal Pumps

High-pressure centrifugal pumps are designed for use in applications requiring high-discharge pressures and low flows. Contractors may use them to wash down equipment on the job site as well as install them on water trailers. Other uses include irrigation and as emergency standby pumps for firefighting applications.

Typically these pumps will discharge around 145 GPM and produce heads in excess of 300 feet. The pump may have a 2- or 3-inch suction port and up to three discharge ports of varying size for added versatility. The impellers used on these pumps are a closed design (Figure 4C) and not open like those used on other types of centrifugal pumps. Similarly the diffuser (Figure 4F) is more compact than a regular volute in order to generate the high discharge pressures.

These pumps by design are not capable of handling any types of solids or even sandy water. Silt, sand or debris would almost immediately clog the pump if allowed to enter into the casing. Additionally, the impeller and diffuser may be made of aluminum rather than wear-resistant cast iron since they are not subject to abrasive materials. It is recommended that a mesh net *always* be placed over the suction strainer if the pump is being used in dirty water.

Trash Centrifugal Pumps

Trash centrifugal pumps get their name from their ability to handle large amounts of debris and are the preferred choice of contractors and the rental industry. The most common sizes are in the 2 to 6-inch range producing flows from 200 to 1,600 GPM and heads up to 150-feet.

The rule of thumb is that a trash pump will generally handle spherical solids up to ½ the diameter of the suction inlet. Solids (sticks, stones and debris) flow through without clogging making them ideal for the water conditions typically found on job sites. Trash pumps handle up to 25% suspended solids by volume.

Trash pumps offer another benefit in that they can be quickly and easily disassembled for service or inspection. While standard pumps require special tools that aren't always available the inside of a trash pump housing can be accessed with common tools.

Customers occasionally ask why a trash pump costs more than standard centrifugal pumps. One big reason is that higher

horsepower engines are needed for trash pumps. The impeller is a cast iron two-vane design (Figure 4B) and a large volute (Figure 4E) is required to handle the higher volume of water and debris. The mechanical seal — like the impeller and volute — is selected for its abrasion resistance and more parts are machined for the casing. While there is a higher initial cost it must be noted that this is recovered through the reduced maintenance over the life of the pump.

Prime-assist pumps are by design trash pumps. Their unique high-flow and high air handling characteristics are well suited for large volume dewatering projects, well point dewatering, sewer bypass applications, and other auto-start applications.

Diaphragm Pumps

Diaphragm pumps use a positive displacement design rather than centrifugal force to move water through the casing. This means that the pump will deliver a specific amount of flow per stroke, revolution or cycle.

Engine-powered versions are the most common and typically use the drive shaft to turn an offset connecting rod that is coupled to a flexible diaphragm. The connecting rod alternately raises (expands) and lowers (contracts) the diaphragm at a rate of 60 cycles per minute (RPM).

A vacuum is created inside the pump casing each time the diaphragm is raised (Figure 5A). This opens the inlet valve and seals the discharge valve allowing water and air to enter the

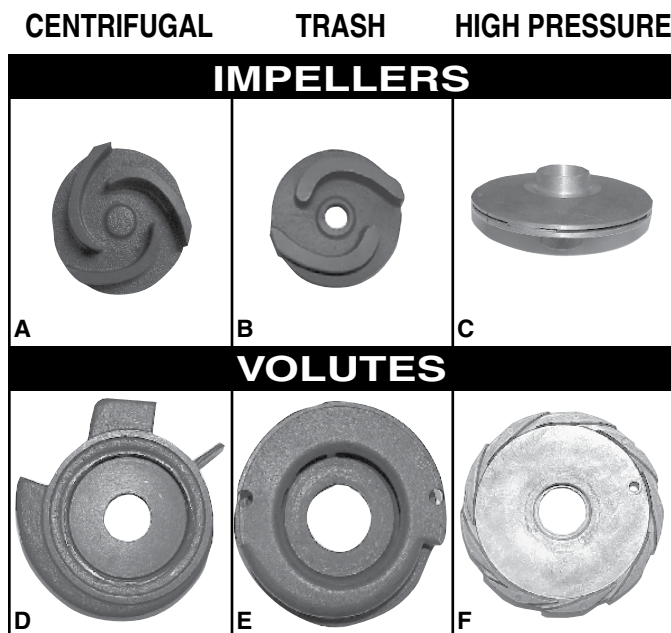
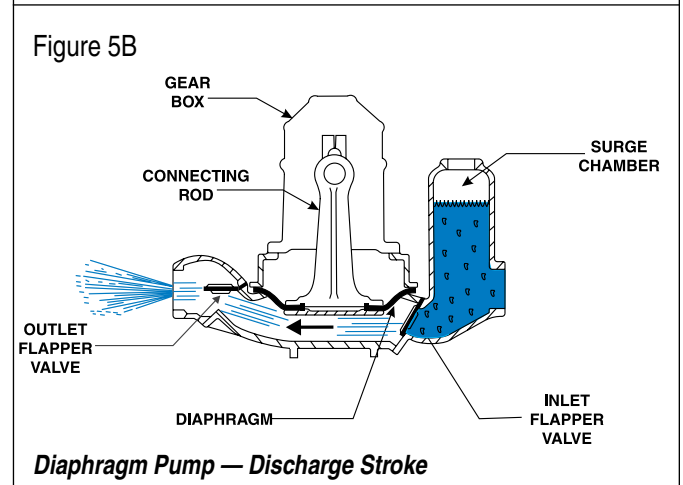
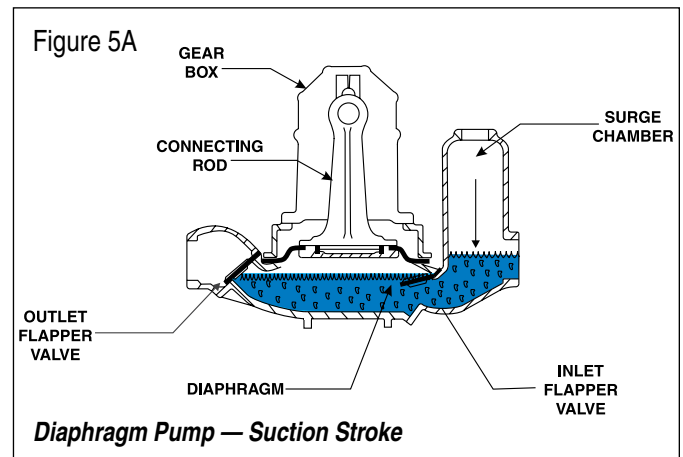

Figure 4



COMMON 2-INCH PUMP DESIGNS



Standard

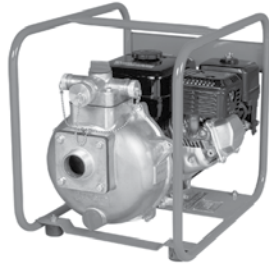

High Pressure

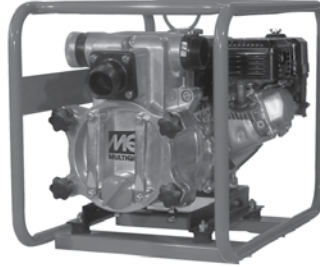

Trash



Diaphragm

pump. When the diaphragm is lowered the resulting pressure seals the inlet and opens the outlet valve purging the pump housing of water and air (**Figure 5B**). Unlike centrifugal designs the water inside the casing is *positively displaced* and no recirculation occurs.

Diaphragm pumps are commonly referred to as mud hogs, mud hens and mud suckers. Their names reflect their popularity for use in applications where shallow depths and slurry water render centrifugal pumps ineffective.

A diaphragm pump provides the lowest rate of discharge and head by comparison of any contractor pump. The most popular are 2 and 3-inch gasoline-powered models producing flows in the range of 50 to 85 GPM. They have the ability to handle air without losing their prime and of handling water with a solid content greater than 25% by volume.

Slow-seepage applications are the most common uses for diaphragm pumps. These conditions exist in any trench or excavation where groundwater seeps slowly into the work site and in areas with high water tables. In these environments centrifugal pumps are unable to perform effectively because their high-discharge volumes combined with low water levels would cause the pumps to quickly lose their prime.

Another design benefit is that diaphragm pumps do not run the risk of being damaged if run dry for long periods of time. Since there is no impeller or volute the only wear parts are the flapper (inlet and outlet) valves along with the diaphragm.

Submersible Pumps

Few items provide as quick a return on investment and as long a work life as submersible pumps. Their compact and streamlined design makes them ideal for wells and other jobs where space is limited. A typical rental company may stock pumps in sizes from 2 to 6-inches producing flows ranging from 45 to 790 GPM and heads up to 138 feet.

Submersibles have the advantage of being able to be work in the water source being pumped. As a result the submersible is not subject to the suction lift limitations of other typical contractor pumps. No suction hose is required helping to save money and time while eliminating a potential source of problems. The pump is limited only by the discharge head it is capable of producing.

The pumps can also be classified by motor size and voltage requirements. Smaller units, with $\frac{1}{3}$ and $\frac{1}{2}$ horsepower 115-volt motors are ideal for homeowner use or light-duty jobs. Experienced dewatering contractors will often choose pumps with 230/460-volt 3-phase motors as they provide higher performance and cost less to run over time.

The pump motors use a vertical shaft to turn the impeller and generate the velocity needed to create the discharge pressure. Water flows in through the bottom and is discharged out the top of the pump casing. Submersible trash pumps use a vortex design that allows the pump to handle some solids without passing through the casing.

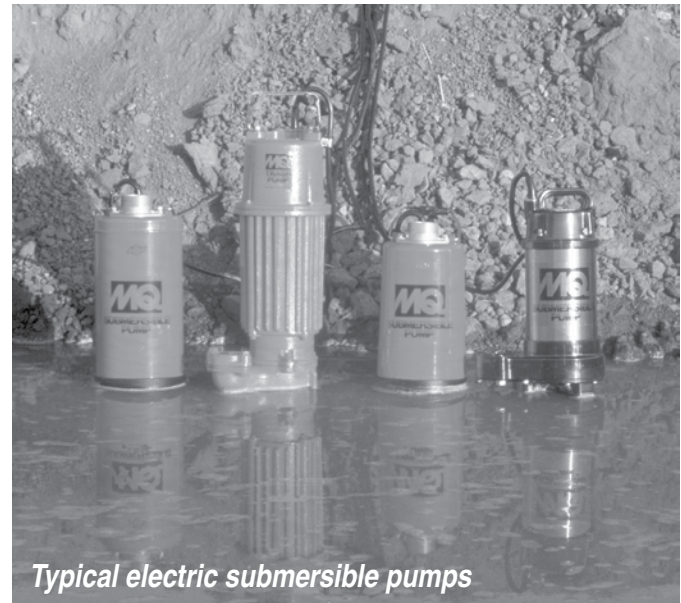

Typical electric submersible pumps

Combining electricity and water obviously brings a certain element of risk. Further, it is difficult and often impossible to know if there is a problem once the pump is submerged. As a result the pump should provide some built-in protections to ensure safety and guard against damage to the equipment.

A high quality pump will have its motor housed in a watertight compartment and equip it with thermal overload sensors that shut down the motor to prevent damage from overheating. Pumps should also be used with GFCI protected circuits.

Some manufacturers may choose to list their pumps with an independent testing laboratory. There are many laboratories

but the most common in North America are Underwriter's Laboratories (UL) and the Canadian Standards Association (CSA).

Maintenance is minimal and generally consists of periodically inspecting the electrical cord and the mechanical sea lubricant. There are none of the concerns common with engine-driven pumps such as noise, fuel or emissions.

Control boxes and float switches are available for unattended operation of submersible pumps. The boxes provide protection against voltage fluctuations and incorrect phasing while the float switches turn the pump on and off according to fluctuating water levels. A number of different accessories are available but care should be taken that they meet the electrical requirements of the pump.

Pump Terminology

As with any field working with pumps requires an understanding of the terminology common to their applications.

It was explained earlier that pumps lift water with the aid of atmospheric pressure then pressurize and discharge it from the casing. The practical suction lift, at sea level, is 25 feet. The published specifications of most pump manufacturers will list this as **maximum suction lift**.

Pump performance is measured in volume as **gallons per minute** and in pressure as **head**. In general a trade off occurs between head and flow with an increase in head causing a decrease in flow or vice versa.

Head refers to gains or losses in pressure caused by gravity and *friction* as water moves through the system (**Figure 6**). It can be measured in lbs/in² (PSI) but is most commonly listed in feet of water in published specifications.

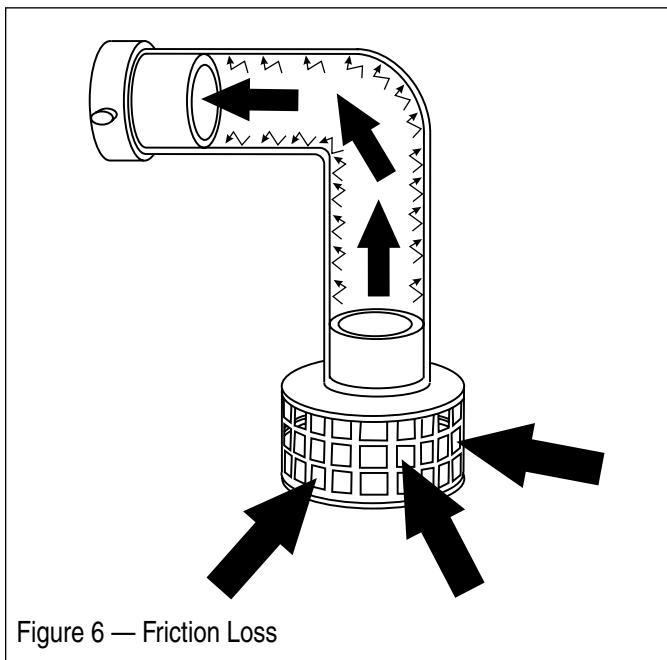

Figure 6 — Friction Loss

To illustrate this consider that a Multiquip 3-inch trash pump is rated with a maximum head of 90-feet. A pump must produce 1 PSI to push a column of water vertically 2.31 feet. Therefore dividing the maximum head rating of a pump by 2.31 will provide the maximum pressure capability of the pump.

$$90 \text{ (ft/head)} \div 2.31 \text{ (ft/head)} = 38.96 \text{ PSI}$$

Similarly multiplying 2.31 by the maximum pressure capability of the pump will provide the maximum head rating of the pump.

$$2.31 \text{ (ft/head)} \times 38.96 \text{ PSI} = 90 \text{ (ft/head)}$$

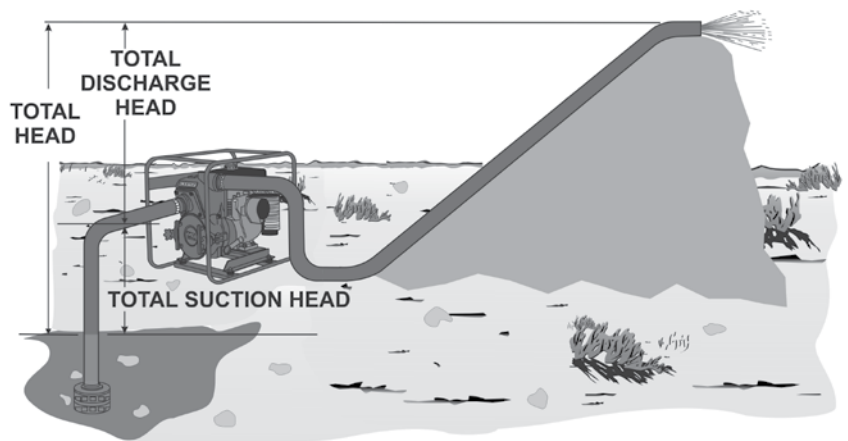

Figure 7

Depending on how the measurement is taken suction lift and head may also be referred to as *static* or *dynamic*. Static indicates the measurement does not take into account the friction caused by water moving through the hose or pipes. Dynamic indicates that losses due to friction are factored into the performance. The following terms are usually used when referring to lift or head.

Static Suction Lift — The vertical distance from the water line to the centerline of the impeller.

Static Discharge Head — The vertical distance from the discharge outlet to the point of discharge or liquid level when discharging into the bottom of a water tank.

Dynamic Suction Head — The static suction lift plus the friction in the suction line. Also referred to as *Total Suction Head*.

Dynamic Discharge Head — The static discharge head plus the friction in the discharge line. Also referred to as *Total Discharge Head*.

Total Dynamic Head — The Dynamic Suction Head plus the Dynamic Discharge Head. Also referred to as *Total Head*.

Pumping Factors

The altitude at which a pump is operated will enhance or diminish its performance. At higher elevations atmospheric pressure is decreased reducing suction lift. For this reason the pump should be located as close to the water source as possible. Table 1 shows suction lift at several elevations.

TABLE 1 — Suction Lift At Various Elevations

Altitude	Suction Lift In Feet			
	10.0	15.0	20.0	25.0
Sea Level	10.0	15.0	20.0	25.0
2,000 Feet	8.8	13.2	17.6	22.0
4,000 Feet	7.8	11.7	15.6	19.5
6,000 Feet	6.9	10.4	13.8	17.3
8,000 Feet	6.2	9.3	12.4	15.5
10,000 Feet	5.7	8.6	11.4	14.3

Altitude affects engine performance as well. A rule of thumb is that gasoline and diesel engines will lose 3% of their power for every 1,000 feet of elevation. This is due to the “thinner air” or lack of oxygen at higher altitudes. The reduced engine speed results in reduced flow and head. Table 2 shows percentage drops in performance as elevation increases.

Many engine manufacturers offer methods of overcoming this loss by offering high altitude cylinder heads, as well as carburetor jets and air cleaners designed for use at higher elevations.

TABLE 2 — Performance Loss At Various Elevations

Altitude	Discharge Flow	Discharge Head
Sea Level	100%	100%
2,000 Feet	97%	95%
4,000 Feet	95%	91%
6,000 Feet	93%	87%
8,000 Feet	91%	83%
10,000 Feet	88%	78%

Water temperature and suction lift have an inverse relationship. As water temperature increases the practical suction lift will decrease, because warm water contains more entrained air, causing the pump to lose its ability to prime. If the water is too warm, it may be necessary to locate the pump below the water level. This creates a net positive suction head (NPSH). Always be cautious when pumping hot water, as it can damage your pump. It is advisable to contact the pump manufacturer to determine the maximum operating temperature.

The Vacuum Test

Each time the pump is returned from a rental, it is wise to run a simple vacuum test to determine the pumping and priming capabilities of your equipment. This test takes only a few seconds to run, and in no way requires a skilled technician.

To perform the vacuum test, the pump case should be filled with water and a small amount of grease applied to the rubber face of the vacuum gauge. The discharge port should be open and free of obstruction. After the engine has been started and brought up to the proper RPM, simply apply the vacuum gauge assembly to the suction opening. In a few seconds, a vacuum will start to develop and the gauge should remain in position during the test.

If the vacuum gauge reads 25", then rest assured that the pump is capable of lifting water 25 feet (assuming that the suction hose and fittings are correctly applied). If this test is performed each time a pump is sent out on a rent, you can eliminate the customer's complaints of the pump's inability to prime.

If the pump has been checked and it pulls 25" of vacuum, then the problem will be elsewhere and you should refer to **Pump Troubleshooting Guide**.



SELECTING THE IDEAL PUMP FOR TYPICAL CONDITIONS

Application	Standard Centrifugal	Diaphragm	Trash	Submersible
Clear Water	X			X
Slimy Water	X	X	X	X
Muck Water	X	X	X	X
Mud Water	X	X	X	
Silt Water	X	X	X	
Abrasive Water	X	X	X	
High Solid Content Water		X	X	
Slow Seepage Ditch Water		X		X
Septic Tank		X	X	
Man Holes	X		X	X

Pump Troubleshooting Guide

Should you receive calls from the field indicating that the pump is not functioning properly, the following list may aid you in determining the problem.

If the pump does not deliver enough water:

- Engine may not be running at the rated speed.
- Strainer, inlet valve or the suction line may be clogged.
- Suction line or fittings may leak air.
- Mechanical seal may be worn and leaking air or water. Check weep hole.
- There may be too much clearance between impeller and the volute due to wear. For best performance refer to manufacturer's recommendations for proper adjustment.
- Lining in the suction hose may be collapsing. This rubber lining inside the fabric layers may have pulled together under the vacuum created by the pump.
- Suction lift may be too high. At a 25-foot lift the pump delivers only about 50% of the water it delivers at a 10-foot lift.
- The suction hose may be too long, causing excessive friction loss and reducing pump capacity.
- Discharge head may be too high. Check hose or pipe friction losses. A larger hose or pipe may correct this condition.

If the pump does not develop enough pressure:

- Engine may not be running at its rated speed.
- Mechanical seal may be leaking. Check weep hole.
- There may be too much clearance between the impeller and pump body or volute due to wear. For good performance, refer to the manufacturer's instructions for proper adjustment.

If the pump does not prime properly:

- Make sure that the pump casing is filled with water.
- Look in the suction line or fittings. Check to see that all fittings are tight in the suction line and make sure there is no leak in the hose itself.
- Mechanical seal may be worn and leaking air.
- Inlet valve rubber may be frozen to the seat.
- Pump may be running too slowly.
- The clearance between the impeller and pump body or volute may be greatly worn. Refer to the manufacturer's instruction manual for proper adjustment.
- Suction lift may be too high. At sea level the pump should not be used on lifts in excess of 25 feet from the level of the water to the center of the impeller. Keep the pump as close to the water source as is safely possible.
- Suction line or suction strainer may be clogged.

- Water may be too warm for the suction lift being used (as the temperature of the water increases above 60°F, the practical suction lift will decrease) making priming difficult. It may be necessary to replace the water in the pump case with fresh cold water.

Making Your Pump Last

The following check list may aid you in keeping your pumps in top condition. Check the following points on a monthly basis:

- Priming speed
- Capacity
- Noise in pump casing
- Gaskets and O-rings
- Shaft seal leakage of air or water
- Hose, hose washers and suction strainer

Check the following performance points on the engine:

- Crankcase oil level
- Spark plug condition
- Air cleaner
- Unusual engine noise
- Proper RPM
- Carburetor adjustment

Every six months, check the impeller for wear, and for clearance between the impeller face and the volute. Refer to the manufacturer's recommendations. Check the shaft seal for wear, as well as the shaft sleeve. Clean the casing and volute passages.

Pump Storage Tips

- Drain the pump casing completely of water to prevent damage from freezing.
- If complete draining is not possible, pour a small amount of anti-freeze into the casing and rotate the pump shaft to ensure mixing.
- Seal suction and discharge ports to prevent the entry of debris or other foreign material.
- If the pump has an oil lubricated seal, drain the oil from the seal cavity and refill with 30-weight non-detergent motor oil.
- For water cooled-seals, place one-half pint of lubricating oil (new or used) through the discharge opening in the pump and turn the engine over several times. This will prevent excessive corrosion and also will keep the mechanical seal lubricated.

Glossary

Air Bound — A condition occurring when a centrifugal pump body is filled with air and a vacuum can no longer be formed allowing water to flow into the pump.

Capacity is the water handling capability of a pump commonly expressed as either gallons per minute (GPM) or gallons per hour (GPH).

Cavitation is the result of vapor bubbles imploding. This occurs when the amount of water flowing into the pump is restricted or blocked.

Cleanout Covers — On trash pumps a removable cover that allows easy access to the interior of the pump casing for removal of any debris.

Dewatering — The removal of unwanted water-clear or dirty but free from hazardous material.

Diffuser — A stationary housing similar to a volute in which the impeller rotates. Compact in design, it enables the pump to produce higher heads/pressures.

Discharge Hose — A collapsible hose used to move the water discharged from the hose.

Discharge Port — Same as the outlet. The point where the discharge hose or pipe is connected to the pump.

Drain Plugs — Removable plugs used to drain water from the pump during periods of inactivity.

Dynamic takes into account motion, as opposed to static.

Flapper Valve — Rubber molded around a steel weight that seals off the inlet or outlet preventing water from either entering or exiting the pump.

Frame — A wraparound tubular steel frame provides protection for the casing and engine. These frames can simplify storage (stacking) and lifting.

Friction Loss refers to reductions in flow due to turbulence as water passes through hoses, pipes, fittings and elbows.

Hazardous Material — Any volatile, explosive or flammable liquid that requires special handling and should not be used with a dewatering pump.

Head — A measurement of pressure typically expressed in feet/head or lb/in²

Impeller — A disk with multiple vanes. It is attached to the pump engine or motor and is used to create the centrifugal force necessary for moving water through the pump casing.

Mechanical Seal — A common wear part that forms a seal between the pump and the engine or motor. Also prevents water from seeping into the engine or motor.

Net Positive Suction Head (NPSH) — positive flow of water to the suction port of a pump.

Performance Curves — chart water flow by comparing total head to flow rate.

Prime — The creation of a vacuum inside the pump casing.

Pump Housing — The pump body or casing. Depending on the design may be made of plastic, aluminum, cast-iron or stainless steel.

Self-Priming — The ability of a pump to purge air from its system and creating an area of low pressure that permits water to flow into the pump casing.

Shock Mounts — Rubber mounts used to dampen vibration from the engine and help prevent the pump from “walking away.”

Skid Mount — Pump and engine mounting mounted on a base.

Slow Seepage — Water that drains slowly into a trench or work area from the surrounding area. Possibly caused from run off or high water tables.

Solids — Any particulate that passes through the pump: mud, sand, rock or other debris.

Static acting by weight not motion, as opposed to dynamic.

Strainer — A fitting at the end of the suction hose that prevents solids from entering the pump larger than what it is capable of passing.

Strain Relief Protector — A support that prevents the electrical cord of a submersible pump from being accidentally pulled out of the casing.

Suction Hose — A reinforced hose used through which water flows into the suction end of a pump.

Suction Port — Same as the inlet. The point where the suction hose or pipe is connected to the pump.

System — the network of hoses, pipes and valves linked to the pump.

Thermal Overload Sensors — A feature built into the motor of submersible pump that shuts it down should the operating temperature become too high.

Viscosity — The resistance to flow of a liquid at a given temperature. High viscosity liquids such as motor oil are more resistant to flow than water.

Volute — A stationary housing inside the pump housing in which the impeller rotates. It is used to separate air and water.

Water Hammer — Energy transmitted from a sudden stoppage in the flow of water out of the pump.

Wear Plate — A replaceable steel insert that fits inside the volute or suction cover of a pump. Helps to form a vacuum with the impeller and reduce the cost of replacement parts.

Weep Hole — A small opening on the underside of the pump where it is joined to the engine. Allows quick detection of a leak before water seeps into the oil sump of the engine.



MULTIQUIP INC.
POST OFFICE BOX 6254
CARSON, CA 90749
310-537-3700 • 800-421-1244
FAX: 310-537-3700
E-MAIL: mq@multiquip.com
www.multiquip.com