

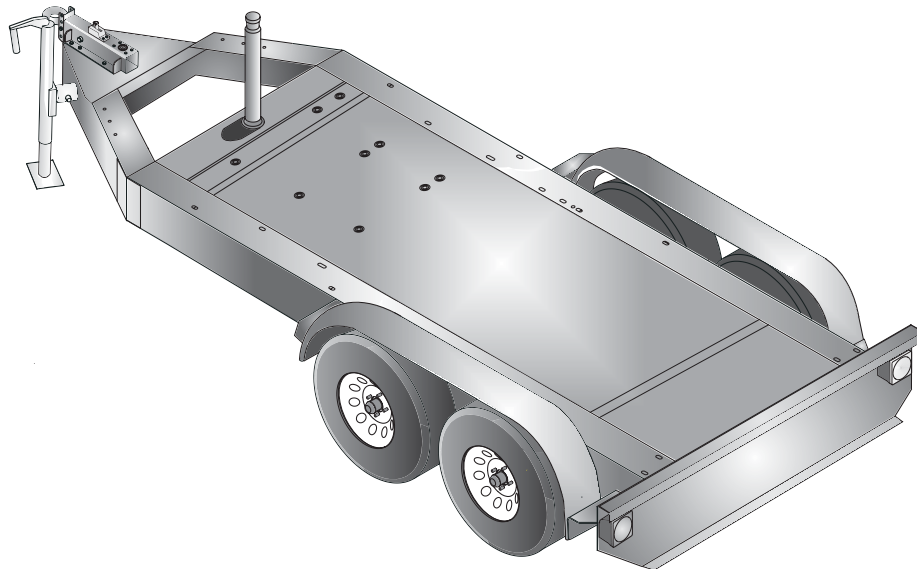

TRLR125XF Tandem Axle Trailer



TRLR125XF Technical Data			
Gross Vehicle Weight Rating (GVWR)	9,000 lbs	Tire Size	ST225/75D15 LR-D
Gross Axle Weight Rating (GAWR)	4,500 lbs (ea.)	Wheel Bolt Pattern	6 Lug on 5.5 in
Actuator Rating	12,500 lbs	Tire Load Rating	2,540 lbs (ea.)
Coupler Rating	See Coupling Options on reverse page	Dimensions (LxWxH)	See Dimensions on reverse page

Standard Trailer Equipment:

- Fits MQ Power Generator Models DCA85SSJU2, DCA100SSVU, DCA125SSI
- Tandem-axle Design with Torsion Type Suspension
- H.D. Welded Steel Frame Construction
- Formed Channel for Generator Mounting and Support
- Integral Fuel Cell; Single-wall Steel Design; 180-gallon Capacity
- Replaceable, Bolt-on Hydraulic Brake Actuator
- Surge Hydraulic-actuated Drum Brakes (all axles)
- Hydraulic Uni-servo Drum Brakes with Free-backing Plates - 12-inch Cluster
- D.O.T. Steel Brake Lines, Brass Tees & Rubber Hydraulic Brake Hoses
- 4-hole Channel Allows 3-position, Adjustable Coupler Height; 4-inches O/A
- Tongue Mounted Swivel Jack with Flat Disc-foot (rated 5,000 pound lift)
- Replaceable, Bolt-on Steel Fenders
- Serviceable Torsion-axle Swing Arms
- Powder Coat Paint Process including: Frame, Channel, Actuator & Fenders
- D.O.T. Approved Tail Lamps, Stop Lamps, Turn Signal Lamps, Side Marker Lamps
- Weatherproof, Rubber Armored, 3-piece Trailer Light Wiring Harness



TRLR125XF Tandem Axle Trailer

Optional Trailer Equipment

- Bolt-on Electric Brake Coupler Plate with Electric-actuated Drum Brakes (all axles)
- Electric Breakaway Safety Device (electric-actuated brakes)
- Adjustable 2-inch or 2 5/16-inch Ball Coupler
- Adjustable 3-inch Pintle-eye Coupler
- Rear Stabilizer Stands
- Tongue Mounted Utility Storage Box
- Anti-Theft Wheel Lock
- Spare Tire with Locking Mount

Coupler Options

3" Pintle Eye
20,000 lbs.



#EE36264

2" Ball Coupler
10,000 lbs.

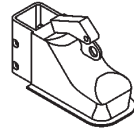

#EE43254

2-5/16" Ball Coupler
14,000 lbs.

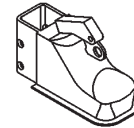

#EE43253

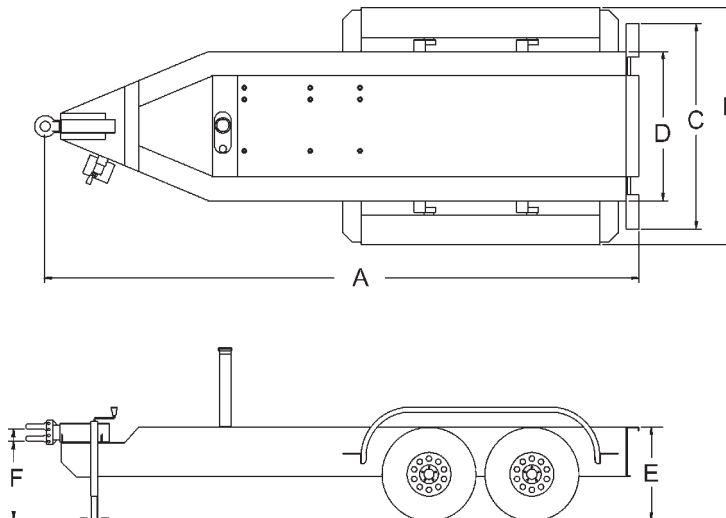

Trailer Dimensions

A	B	C	D	E	F	
					Min	Max
179 in.	71.5 in.	62 in.	45 in.	28 in.	23 in	27 in.

Trailer Weight

without fuel	with fuel
1,920 lbs (871 kg) *	3,198 lbs (1,452 kg) *

* Weight is approximate

Your MQ Power dealer is:

Cessco Inc.
4222 NE Columbia Blvd.
Portland, OR 97218



Toll Free: 1-800-882-4959



MQ POWER

POST OFFICE BOX 6254
CARSON, CA 90749
310-537-3700 • 800-421-1244
FAX: 310-632-2656
E-MAIL: mqpowers@multiquip.com
WEBSITE: www.mqpowers.com