

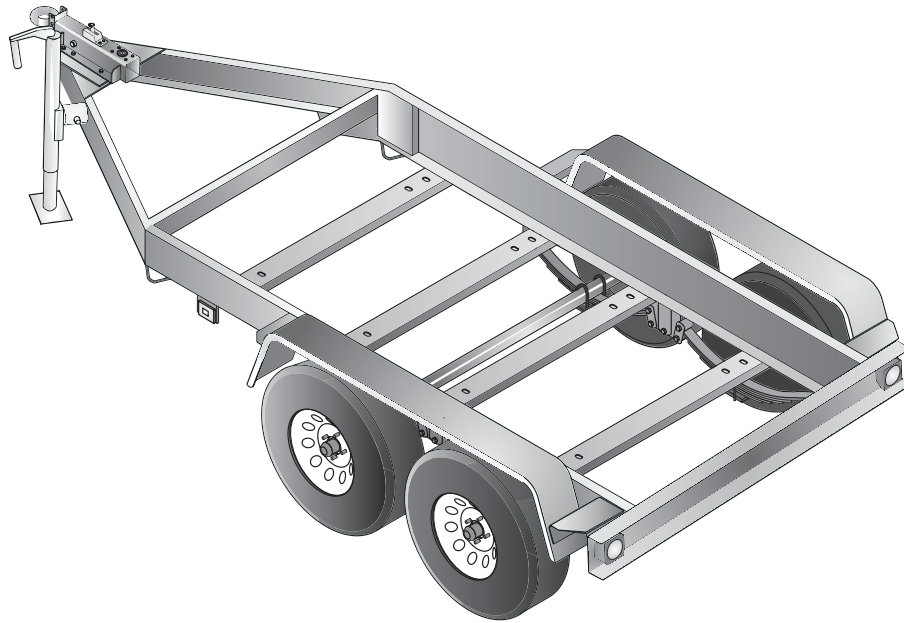

TRLR45US2 Tandem Axle Trailer



TRLR45US2 Technical Data			
Gross Vehicle Weight Rating (GVWR)	7,000 lbs	Tire Size	ST205/75D14 LR-C
Gross Axle Weight Rating (GAWR)	3,500 lbs (ea.)	Wheel Bolt Pattern	5 Lug on 4.5 in
Hydraulic Actuator Rating	8,000 lbs	Tire Load Rating	1,760 lbs (ea.)
Coupler Rating	See Coupler Options Table on next page	Dimensions (LxWxH)	See Dimensions Table on next page

Standard Trailer Equipment

- Fits MQ Power Generator Model DCA25USIXF, DCA45USI
- Tandem-axle Design with Leaf Spring Suspension
- H.D. Welded Steel Frame Construction
- Structural Channel for Generator Mounting and Support
- Replaceable, Bolt-on Hydraulic Brake Actuator
- Surge Hydraulic-actuated Drum Brakes (all axles)
- Hydraulic Uni-servo Drum Brakes with Free-backing Plates - 10-inch Cluster
- D.O.T. Steel Brake Lines, Brass Tees & Rubber Hydraulic Brake Hoses
- 4-hole Channel Allows 3-position, Adjustable Coupler Height; 4-inches O/A
- Tongue Mounted Swivel Jack with Flat Disc-foot (rated 3,000 pound lift)
- Replaceable, Bolt-on Steel Fenders
- Powder Coat Paint Process including: Frame, Channel, Actuator & Fenders
- D.O.T. Approved Tail Lamps, Stop Lamps, Turn Signal Lamps, Side Marker Lamps
- Weatherproof, Rubber Armored, 3-piece Trailer Light Wiring Harness



TRLR45US2 Tandem Axle Trailer

Optional Trailer Equipment

- Bolt-on Electric Brake Coupler & Channel Plate with Electric-actuated Drum Brakes (all axles)
- Electric Breakaway Safety Device (electric-actuated brakes)
- Adjustable 2-inch Ball Coupler
- Adjustable 2 5/16-inch Ball Coupler
- Adjustable 3-inch Pintle-eye Coupler
- Rear Stabilizer Stands
- Tongue Mounted Utility Storage Box
- Spare Tire with Locking Mount
- Anti-Theft Wheel Lock

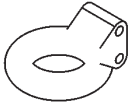
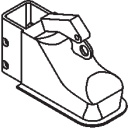
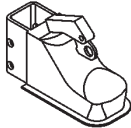
Coupler Options	
3" Pintle Eye 20,000 lbs. #EE36264	
2" Ball Coupler 10,000 lbs. #EE43254	
2-5/16" Ball Coupler 14,000 lbs. #EE43253	

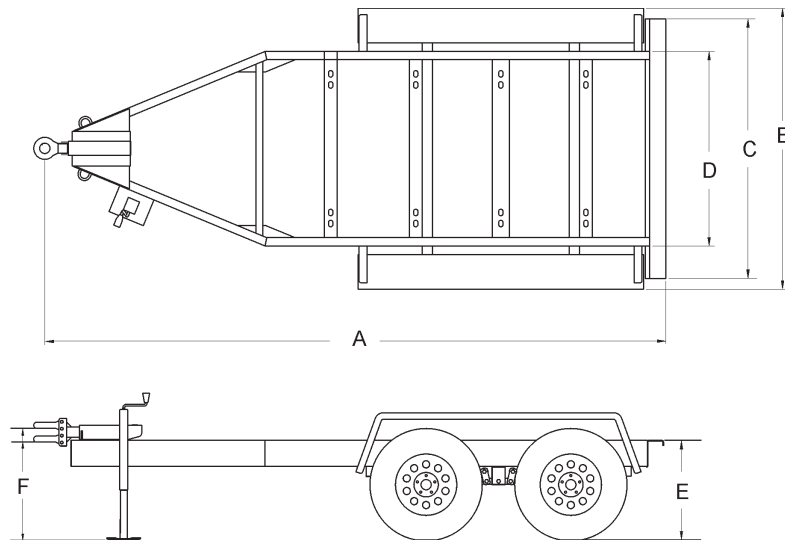

Trailer Dimensions						
A	B	C	D	E	F	
					Min	Max
142.4	65 in.	60 in.	45 in.	23 in.	23.6	27.6 in.
Trailer Weight						
860 lbs (390 kg)*						

* Weights are approximate

Your MQ Power dealer is:



MQ POWER
 POST OFFICE BOX 6254
 CARSON, CA 90749
 310-537-3700 • 800-421-1244
 FAX: 310-632-2656
 E-MAIL: mqpower@multiquip.com
 WEBSITE: www.mqpower.com