

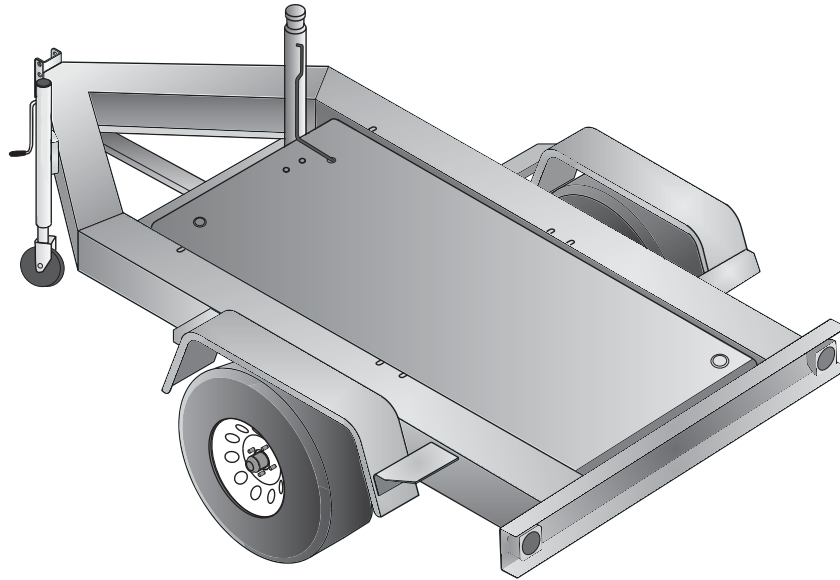

TRLRMPXF Single Axle Trailer



TRLRMPXF Technical Data			
Gross Vehicle Weight Rating (GVWR)	2,000 lbs	Tire Size	ST175/80D13 LR-C
Gross Axle Weight Rating (GAWR)	2,000 lbs (ea.)	Wheel Bolt Pattern	5 Lug on 4.5 in
Coupler Rating	See Coupling Options on reverse page	Tire Load Rating	1,360 lbs (ea.)

Standard Trailer Equipment

- Fits MQ Power Generator Model DA7000, DCA10SPX, TLG12SPX, DCA15SPX
- Single-axle Design with Leaf Spring Suspension
- H.D. Welded Steel Frame Construction
- Integral Fuel Cell; Single-wall Steel Design, 28 Gallon Capacity
- Formed Channel for Generator Mounting and Support
- 4-hole Channel Allows 3-position, Adjustable Coupler Height; 4-inches O/A
- Tongue Mounted Swivel Jack with Caster (rated 1,000 pound lift)
- Replaceable, Bolt-on Steel Fenders
- Powder Coat Paint Process including: Frame, Channel, Actuator & Fenders
- D.O.T. Approved Tail Lamps, Stop Lamps, Turn Signal Lamps, Side Marker Lamps



TRLRMPXF Single Axle Trailer

Optional Trailer Equipment

- Adjustable 2-inch Ball Coupler
- Adjustable 2 5/16-inch Ball Coupler
- Adjustable 3-inch Pintle Eye Coupler
- Rear Stabilizer Stands
- Tongue Mounted Utility Storage Box
- Spare Tire with Locking Mount
- Anti-Theft Wheel Lock

Coupler Options

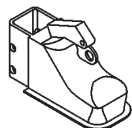
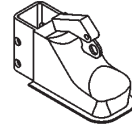
3" Pintle Eye 20,000 lbs. #EE36264	
2" Ball Coupler 6,000 lbs. #29228	
2-5/16" Ball Coupler 14,000 lbs. #EE43253	

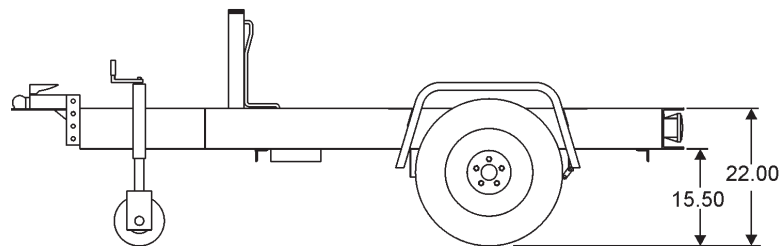
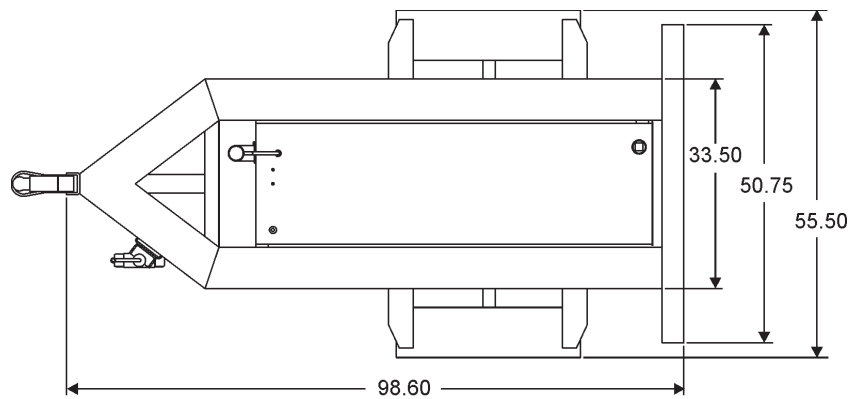

Trailer Weight	
Without fuel	With fuel
347 lbs (157.5 kg)	545 lbs (247 kg)

Your MQ Power dealer is:

Cessco Inc.
4222 NE Columbia Blvd.
Portland, OR 97218



Toll Free: 1-800-882-4959



MQ POWER

POST OFFICE BOX 6254

CARSON, CA 90749

310-537-3700 • 800-421-1244

FAX: 310-632-2656

E-MAIL: mqpower@multiquip.com

WEBSITE: www.mqpower.com