

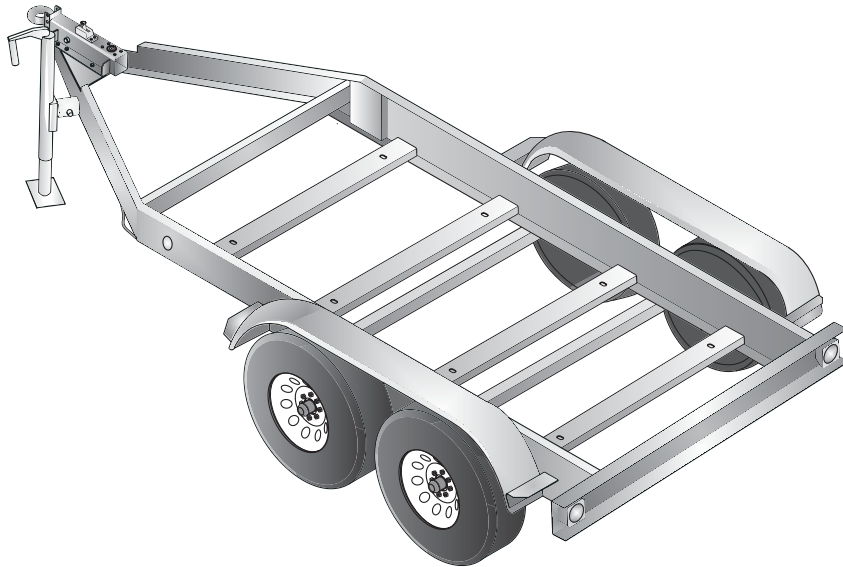

TRLR150US Tandem Axle Trailer



TRLR150US Technical Data			
Gross Vehicle Weight Rating (GVWR)	11,000 lbs	Tire Size	ST235/80R16 LR-E
Gross Axle Weight Rating (GAWR)	6,000 lbs (ea.)	Wheel Bolt Pattern	8 Lug on 6.5 in
Actuator Rating	12,500 lbs	Tire Load Rating	3,500 lbs (ea.)
Coupler Rating	See Coupling Options on reverse page	Dimensions (LxWxH)	See Dimensions on reverse page

Standard Trailer Features

- Fits MQ Power Generator Models DCA125USI, DCA150USJ
- Tandem-axle Design with Torsion Type Suspension
- H.D. Welded Steel Frame Construction
- Structural Channel for Generator Mounting and Support
- Replaceable, Bolt-on Hydraulic Brake Actuator
- Surge Hydraulic-actuated Drum Brakes (all axles)
- Hydraulic Uni-servo Drum Brakes with Free-backing Plates - 12-inch Cluster
- D.O.T. Steel Brake Lines, Brass Tees & Rubber Hydraulic Brake Hoses
- 4-hole Channel Allows 3-position, Adjustable Coupler Height; 4-inches O/A
- Tongue Mounted Swivel Jack with Flat Disc-foot (rated 5,000 pound lift)
- Replaceable, Bolt-on Steel Fenders
- Serviceable Torsion-axle Swing Arms
- Powder Coat Paint Process including: Frame, Channel, Actuator & Fenders
- D.O.T. Approved Tail Lamps, Stop Lamps, Turn Signal Lamps, Side Marker Lamps
- Weatherproof, Rubber Armored, 3-piece Trailer Light Wiring Harness



TRLR150US Tandem Axle Trailer

Optional Trailer Equipment

- Bolt-on Electric Brake Coupler Plate with Electric-actuated Drum Brakes (all axles)
- Electric Breakaway Safety Device (electric-actuated brakes)
- Adjustable 2 5/16-inch Ball Coupler
- Adjustable 3-inch Pintle-eye Coupler
- Rear Stabilizer Stands
- Tongue Mounted Utility Storage Box
- Anti-Theft Wheel Lock
- Spare Tire with Locking Mount

Coupler Options

3" PINTLE EYE
20,000 lbs

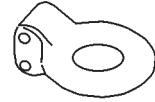

#EE36264

2-5/16" BALL COUPLER
14,000 lbs

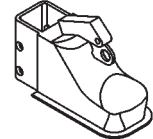

#EE43253

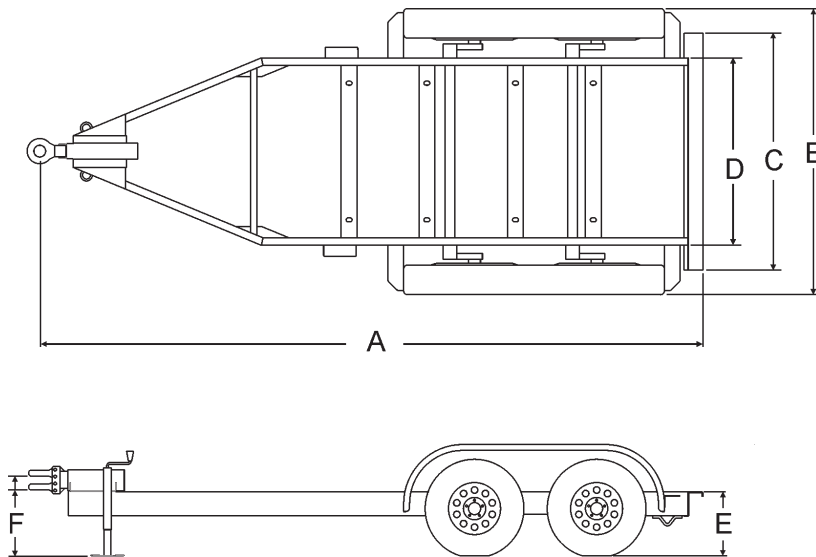

Trailer Dimensions

A	B	C	D	E	F	
					Min	Max
184 in.	83 in.	70 in.	56 in.	24 in.	20 in.	24 in.

Trailer Weight

1,772 lbs (445 kg)*

* Weight is approximate

Your MQ Power dealer is:



MQ POWER
 POST OFFICE BOX 6254
 CARSON, CA 90749
 310-537-3700 • 800-421-1244
 FAX: 310-632-2656
 E-MAIL: mqpower@multiquip.com
 WEBSITE: www.mqpower.com